

University of Groningen
Faculty of Mathematics and Natural Sciences

BACHELOR THESIS



Tobias Mulder

Conformal invariance and Nambu-Goldstone bosons

Supervisor Physics: Prof. Dr. D. Boer
Supervisor Mathematics: Dr. K. Efsthathiou
Study programme: Mathematics and Physics

Groningen 2017

ABSTRACT

Employing the language of Lie Groups and Lie Algebras to describe conformal transformations, we identify in a conformal invariant theory Noether charges as the generators of these transformations. We establish the Goldstone theorem and the rules for counting the number of independent Goldstone modes in general for systems with and without Lorentz invariance, and discuss various theorems regarding the counting of these Goldstone modes. We conclude with a discussion on conformal invariance, relating the dilatation and special conformal transformation in systems for which translational invariance is not entirely broken.

ACKNOWLEDGMENTS

I would like to thank both Prof. Boer and Dr. Efstathiou for their guidance, questions and feedback. Their input has helped me a great deal in my understanding of finding the right answers and asking the right questions.

Contents

Abstract	i
Acknowledgments	ii
Introduction	2
Introduction - Mathematics	2
Introduction - Physics	3
1 Symmetry Groups, Actions and Representations	4
1.1 Groups and Symmetries	4
1.2 Representation Theory and Lie Groups	6
1.2.1 Representation Theory	7
1.2.2 Lie Groups	13
1.2.3 $SO(3, \mathbb{R})$	20
1.3 Conformal Symmetry	24
1.3.1 An example from complex analysis	24
1.3.2 The conformal group	25
2 Symmetry Groups in Physics	31
2.1 Noether's Theorem	31
2.1.1 The Energy Momentum Tensor	34
2.2 Symmetry breaking	34
2.3 The Goldstone Theorem	35
2.3.1 On spontaneous symmetry breaking	36
2.3.2 Effective action formalism	37
3 Nambu-Goldstone bosons: a review	40
3.1 Nambu-Goldstone bosons in (non)relativistic theories	41
3.1.1 Symmetry transformations and operators	41
3.1.2 The Goldstone Theorem for internal symmetries	43
3.1.3 Non-relativistic Goldstone bosons	45
3.2 Spacetime Symmetries	50
4 Nambu-Goldstone bosons and Conformal symmetries	53
4.1 Scale-invariant theories	53
4.2 Scale invariance and conformal invariance - a first relation	55
4.3 Dilatations and Goldstone bosons	56
4.4 Conformal transformations, a final discussion	56

Conclusion and Outlook	59
Appendices	60
A Notation	61
B Group Theory	62
C Quantum Mechanics	64

Introduction

In both mathematics and physics, the notion of symmetry can be a guidance in the forming of the theory one is interested in. Varying from connections between various algebraic structures to properties of thermodynamic systems, understanding a form of symmetry present can greatly help in describing a structure.

In this thesis, we will explore various notions of symmetry. We will discuss continuous transformations acting on vector spaces represented by Lie Groups. The notion of Lie Algebras will be used to study the angle-preserving *conformal* transformations. We will identify the group corresponding to these transformations by identifying the corresponding Lie Algebra. A natural definition of symmetries in physical systems which admit a variational formalism will be found, resulting in conserved quantities which generate these transformations.

Subsequently, we will introduce the notion of *broken* symmetries in the context of Quantum Field Theory, resulting in massless modes known as Nambu-Goldstone bosons, which are discussed with a focus on broken conformal invariance.

Introduction - Mathematics

The mathematical basis underlying this thesis is developed in the first chapter, where both Representation Theory and Lie Groups are discussed. However, we will see that the formalism is used throughout the thesis. The first chapter focuses on a formal development of both the language of representation theory and Lie Groups, which explores the power of representing a group by a linear operator on a vector space. We observe that the vague notion of a continuous group is given a precise definition in the form of a Lie Group, unifying algebraic and geometric aspects of symmetry transformations. The language of Lie Groups allows us to define a transformation group in terms of tangent spaces on a manifold and commutation relations of basis elements in this tangent space. The results in chapter will be applied to the *Conformal Group* in the final section of the first chapter.

Having developed the language of Lie Groups, we will apply their tools to physical systems which admit a variational formalism in terms of the Lagrangian and the action, leading to a natural notion of symmetry and specific Lie Algebra through Noether's Theorem. We will see that various forms of symmetries will lead to Goldstone bosons in the language of Quantum Field Theory. Exploring

relations between the various generators of the conformal group will translate in theorems regarding the number of this type of bosons.

Introduction - Physics

The Lagrangian formalism, equivalent to the laws of Newton at the classical level, is the most powerful tool when studying the dynamics of (quantum) field theories. Symmetry is easily defined as invariance of the corresponding action $S = \int d^4x \mathcal{L}$, leading to the celebrated theorem by Emmy Noether which relates these symmetries to conserved currents and charges. We will see that precisely these charges will generate the symmetry transformations. A formal treatment of these transformations and their generators as manifolds equipped with a group structure is given in terms of Lie Groups and Algebras in the first chapter.

In the second chapter we will see that symmetry breaking at vacuum states in QFT will result in a particular massless boson (the Nambu-Goldstone) bosons. We will review existing theorems on (the counting of) these bosons for both Lorentz invariant and non-invariant theories.

The last chapter will be dedicated to the conformal symmetry group. This group naturally arises as the symmetry group of a free (in the sense of no charges) theory of electromagnetism and is an extension of the Poincaré group. The conformal symmetry is also of major importance in contemporary theories of gravity and electroweak interactions.

Chapter 1

Symmetry Groups, Actions and Representations

In order to arrive at a thorough treatment of various symmetries, a motivation for and introduction to the language of representation theory of Lie Groups is given in this chapter. Subsequently a classification of various symmetries and their representations will be given. We will give an in-depth treatment of conformal symmetry and scale invariance in the last section of this chapter.

Note: Throughout this and the following chapters, we assume an undergraduate level of knowledge in group theory. For readers to whom this subject is unknown, we refer to Appendix A, in which the required knowledge is summarized, or to the extensive amount of literature available, for example Lang (2005, Chapter 2).

1.1 Groups and Symmetries

The language of group theory comes quite natural to the notion of symmetries. Consider for example a simple geometric figure as the square with corner points labeled by A, B, C and D depicted in the following figure:

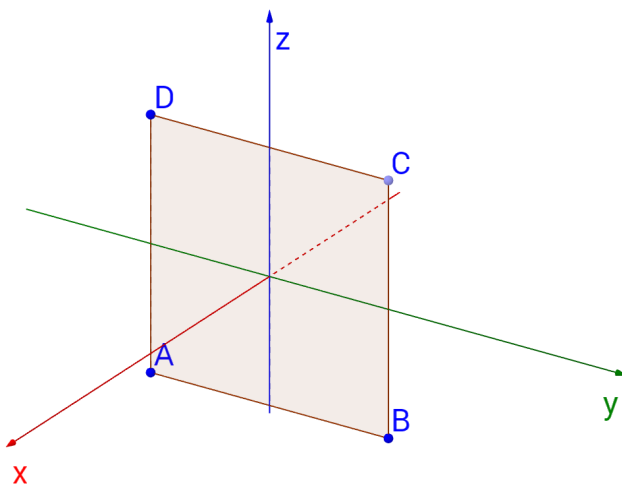

Figure 1.1: A square with undirected sides

We may want to look at the rotational transformations which leave the square invariant in this coordinate system.

As the corner points are indistinguishable (the labels are merely a tool, not a property of the object) we may note that rotations of a multiple of 90 deg (counterclockwise) around the x-axis leave the square invariant. We may denote these rotations as c_1 for a rotation of 90 deg, c_2 for a rotation of 180 deg and so on. But as we only want to consider rotation modulo 360 deg we conclude the relevant rotations are c_1, c_2 and c_3 .

This does not yet identify all rotational transformations which leave this square invariant. There are also the 180 deg rotations around AC and BD , as well as the 180 deg rotations around the z- and y-axis. We may label the latter as b and see we can obtain the other three as follows:

Rotation around	Equivalent to
BD	bc_1
z-axis	bc_2
AC	bc_3

Table 1.1: Remaining invariant transformations in undirected square

The only rotational transformation left is the identity operation e . As suggested by the previous table, the transformations indeed form a group, the symmetry group of the square. This particular group, usually denoted by D_4 , has elements $\{e, c, c^2, c^3, b, bc, bc^2, bc^3\}$.

Here we used notation familiar in group theory by setting $c_1 = c$ and noting $c_{k=2,3} = c^k$ if we define the group multiplication to be the successive application of rotations. We can now check this is a group by simply writing out its multiplication table using geometric arguments. This group, D_4 is an example of a *dihedral* group D_n , the symmetry group of n -sided polygons.

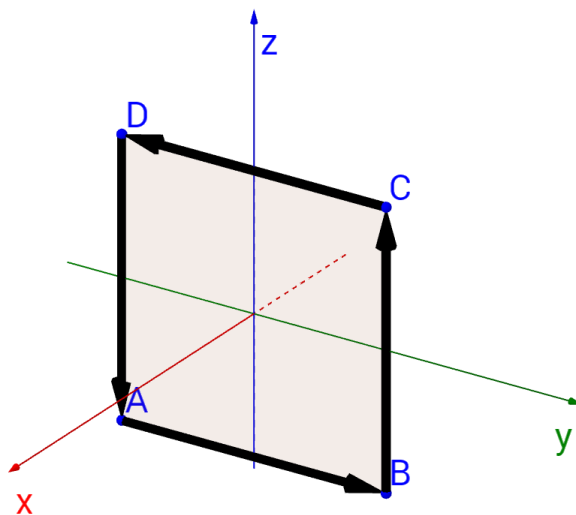

Figure 1.2: A square with directed sides

We will now consider a slightly modified version of our example, a square with directed sides. As additional requirement for invariance of this object we demand the direction of the line segments to be unchanged in the coordinate system. The square is depicted in Figure 1.2.

The only rotations that are left leaving this square invariant are $C_4 = \{e, c, c^2, c^3\}$, a proper subgroup of D_4 . This is an example of symmetry breaking, the symmetry group of our system (which is just a square) breaks down to a subgroup when requiring the sides to be directed. Apart from identifying a subgroup of D_4 , we can work out its conjugacy classes to be $^1(e), (b), (c)$ and its generators $\{b, c\}$ as familiar in group theory.

This example serves to illustrate the fundamental idea in representation theory - we are able to write each element in the group C_4 as a matrix. Denoting the corner points by their position in the yz -plane, i.e.

$$A = \begin{pmatrix} -1 & \\ & -1 \end{pmatrix}.$$

It is straightforward to see we can represent

$$c = \begin{pmatrix} 0 & -1 \\ 1 & 0 \end{pmatrix}, \quad c^2 = \begin{pmatrix} -1 & 0 \\ 0 & -1 \end{pmatrix}, \quad c^3 = \begin{pmatrix} 0 & 1 \\ -1 & 0 \end{pmatrix} \quad \text{and} \quad c^4 = e = \begin{pmatrix} 1 & 0 \\ 0 & 1 \end{pmatrix}.$$

acting on the corner points. In fact, the group C_4 is isomorphic to this set of matrices as is clear when multiplying the matrix representations.

1.2 Representation Theory and Lie Groups

The example explored in the previous section is one regarding a discrete symmetry - only a finite number of transformations was possible. Clearly, this is only a particular subset of all transformations one can think of. We could also rotate the square around any axis by an angle θ which we may pick to be any number in $[0, 2\pi)$. These rotations can still be expected to form a group, with its elements having a matrix representation, now depending on a continuous parameter. A very important class of such groups are the Lie Groups.

Whether these transformations form a symmetry group depends on our notion of invariance. This can be adopted such that we are satisfied with any transformation that leaves the square a rigid square. This results in the group of all translations, uniform rescaling and rotations as a symmetry group.

This section will serve as a formal exploration of the study of Lie Groups and their representations, based on Jones (1998), Fulton and Harris (2005, Chapter 1-4, 7-10), Kirillov, Chapter 2 and 4 and Duistermaat and Kolk (2000, Chapter 1 and 4). The introduction in this section will be far from complete, and will

¹In general, conjugacy classes are elements of the "same type". In this case we have a finite group and we can thus compute every element of the form gxg^{-1} , giving indeed the conjugacy classes as stated.

mainly serve as a reference for the remainder of these thesis. For more elaborate introductions, one can follow these references.

1.2.1 Representation Theory

In the example of the square, it turned out the group of symmetry transformations could be represented by matrices, thus linear mappings on a vector space. This study of these representations is called representation theory. This subsection will serve as a basic and formal introduction to this field. The content of this subsection is based on [Jones (1998)] and [Fulton and Harris (2005)].

Definition 1.1 (Representation). A representation of a group G on a n -dimensional vector space V is a homomorphism $\rho : G \rightarrow \mathbf{GL}(V)$ of the group to the (group of) automorphisms on V . The dimension of V is called the degree of the representation.

Representations A and B are equivalent if there exists $S \in \mathbf{GL}(V)$ such that for all $g \in G$ $A(g) = SB(g)S^{-1}$.

A representation ρ is trivial when $\rho(g)(v) = v$ for all $v \in V$ and all $g \in G$. It is faithful when G is isomorphic to $\rho(G)$.

Remark. One may encounter various notations and terminology. The element in $\mathbf{GL}(V)$ corresponding to $g \in G$ is called the representation of g (under ρ). Often the map ρ is omitted from notation, denoting the action of a representation of $g \in G$ on $v \in V$ as gv . We see a representation of G induces a structure on V as a G -module (see Appendix A). In literature the vector space V (as in [Fulton and Harris (2005)]) may be called the representation of G . In this section, so we will refer to both V and ρ as a representation, the former only if no ambiguity is present. The vector space V is, unless stated otherwise, assumed to be over the field of complex scalars \mathbb{C} .

Example (Representations on \mathbb{R}^n and \mathbb{C}^n). If we set $V = \mathbb{R}^n$ or \mathbb{C}^n in the previous definition, we see representations of any group to be elements of $\mathbf{GL}(\mathbb{R}^n)$ or $\mathbf{GL}(\mathbb{C}^n)$ (called the general linear group) - the set of $n \times n$ invertible matrices with real or complex entries. These will be the main examples of representations encountered throughout this thesis.

The benefit of representing a group by its action on a vector space is the additional structure one has on a vector space. One can form a basis, take an inner product (which induces a norm and metric) and decompose a vector space into subspaces. Precisely these properties are key in developing the theory in the upcoming sections.

Reducible and irreducible representations

Having obtained an orthonormal basis $\{e_i\}_{i=1,\dots,n}$ for V we can write any representation of an element $g \in G$ as a matrix, i.e.,

$$\rho(g) = \begin{pmatrix} A(g) & C(g) \\ D(g) & B(g) \end{pmatrix} \tag{1.1}$$

with A a $k \times k$ matrix, C of dimension $k \times n - k$, D of dimension $n - k \times k$ and B of dimension $n - k \times n - k$. Such a representation is called *reducible* when $D = O$ (with O the appropriate null matrix). Note that A and B themselves constitute representations of G . In the case of $C = D = O$, one can decompose the n -dimensional representation ρ into the sum of two representations acting on subspaces of V . This decomposition is the main idea of this subsection. To fully develop the theory we need a couple of definitions.

Definition 1.2 (Subrepresentations and irreducible representations). Given a representation ρ of a group G we say there exists a (proper) *subrepresentation* if there is a proper linear subspace $U \subset V$ such that U is closed ($\rho(g)(u) \in U$ whenever $u \in U$) under the action of the group, i.e. U is a submodule of V . A representation is called *irreducible* if it has no subrepresentation.

The subrepresentation can, in principle, be constructed if one finds an orthonormal basis for the k -dimensional subspace U , extends this to a basis for V and find the matrix notation for ρ as in (1.1). The subrepresentation will be of the form $\rho_U(g) = \begin{pmatrix} A(g) & 0 \\ 0 & \not\equiv \end{pmatrix}$ or simply by $A(g)$ itself, where $A(g) \in \mathbf{GL}(\mathbb{R}^k)$. It is clear that in the notation of (1.1) for reducible representations a subrepresentation is induced by $B(g)$ as for $D = O$ there is an invariant $(n - k)$ -dimensional subspace on which $B(g)$ acts.

Definition 1.3 (Decomposable representations). For a group G with representation ρ , a reducible representation $\rho(g) \in \mathbf{GL}(V)$ of $g \in G$ is called *decomposable* if there exists a proper submodule $W \subset V$ for which both W and its orthogonal complement, W^\perp are closed under $\rho(g)$. The representation ρ is called decomposable if $\rho(g)$ is decomposable for all $g \in G$.

Remark. In this definition we have assumed an inner product defined on the vector space V , such that it makes sense to talk about W^\perp as the set $W^\perp := \{v \in V \mid (w, v) = 0 \ \forall w \in W\}$. In fact, we have assumed this inner product when introducing an orthonormal basis.

As we can write $V = W \oplus W^\perp$ the argument made earlier can be reversed to conclude a decomposable representation can be written in the form of (1.1) with $C = D = O$ for an appropriate basis of V .

Definition 1.4 (Unitary and Hermitian Transformations). Given an inner product on a vector space V , we define a $T \in \mathbf{GL}(V)$ to be *unitary* when $(u, v) = (Tu, Tv)$ for all $u, v \in V$. We define T to be *Hermitian* when $(Tu, v) = (u, Tv)$ for all $u, v \in V$.

In the case of $V = \mathbb{C}^n$ we see these definitions correspond precisely to the $n \times n$ -matrices A for which $A^\dagger := (A^*)^T = A^{-1}$ and $A^\dagger = A$ respectively.

So far we have introduced the notion of a reducible representation (in terms of matrix notation) and given a formal definition of an *irreducible* representation. We will now show that for finite groups this terminology is justified, i.e. the reducible representations are precisely those we can decompose into subrepresentations and as such are not irreducible. We will start with the following proposition:

Proposition 1.5 (Decomposability for unitary operators). *Given a group G with a representation $\rho : G \rightarrow \mathbf{GL}(V)$. For any unitary $\rho(g) = U \in \mathbf{GL}(V)$ which is reducible, U is decomposable.*

Proof. We follow the proof as in [Jones (1998), pg. 53] Let $\rho(g)$ be such a representation. As noted before, we have an invariant submodule W (upon which $B(g)$ in the matrix notation (1.1) acts). Now let W^\perp be its orthogonal complement. We have, as $U(g)$ unitary for all $x, y \in V$:

$$(Ux, y) = (x, U^{-1}y) \quad (\text{as } U^{-1}x \in V)$$

Let $w \in W, z \in W^\perp$. We have:

$$(Uz, w) = (z, U^{-1}w) \text{ but } W \text{ is an invariant submodule,} \\ \text{so } U^{-1}w := \bar{w} \in W$$

Now $(Uz, w) = (z, \bar{w}) = 0$ follows directly, so W^\perp is also an invariant submodule. This shows any unitary representation is decomposable. \square

Remark. From Definition 1.1 it is clear U^{-1} exists and is given by $\rho(g^{-1})$, as ρ is a homomorphism.

Having established our desired result for unitary representations, we carry on to extend this to an arbitrary representation. There are multiple ways to do this, the most common and easy is to introduce the *group-invariant inner product*. This inner product is constructed from an original inner product (\cdot, \cdot) by $\{x, y\} = \frac{1}{|G|} \sum_{g \in G} (\rho(g)x, \rho(g)y)$ where we adopted our usual notation with $x, y \in V$.

Theorem 1.6 (Maschke's Theorem). *For a finite group G with reducible representation $\rho : G \rightarrow \mathbf{GL}(V)$, (V being a finite-dimensional vector space) ρ is decomposable, i.e. there exists a proper submodule W of V such that both W and W^\perp are invariant under ρ .*

Proof. A proof of this Theorem may be found in [Fulton and Harris (2005), Chapter 3]. It follows from working out the group-invariant inner product which is unitary and invoking Proposition 1.5. \square

Corollary 1.7. *Any representation of a finite group is a direct sum of irreducible representations.*

Proof. This follows directly from the previous theorem. As we can decompose reducible representations into subrepresentations, irreducibility is the negation of reducibility for finite groups. So either our representation is irreducible (in which the direct sum is trivial) or we can decompose it into a direct sum of subrepresentations, which are:

- Reducible, in which case we can decompose it further until irreducibility (note that one-dimensional subrepresentations will always be irreducible) is achieved
- Irreducible, in which case the claim clearly holds.

□

The property as stated above is often referred to as *complete reducibility* or *semisimplicity*. As we ended the introduction of this section with a discussion on continuous transformations, results regarding finite groups might not seem to get us very far. However, the results obtained also hold for the very important class of *compact* groups. As it turns out the - to be discussed - conformal group allows for a compactification which makes these results relevant.

So far we have established the existence of a decomposition into irreducible components. We will now establish uniqueness (in a sense which will become evident shortly) of this decomposition following from a famous lemma (as adapted from [Fulton and Harris (2005), Chapter 1.2]):

Lemma 1.8 (Schur's lemma). *Given $\rho_V : G \rightarrow \mathbf{GL}(V)$ and $\rho_W : G \rightarrow \mathbf{GL}(W)$ representations of a group G and a G -module homomorphism $\phi : V \rightarrow W$. Then we have:*

1. *Either ϕ is an isomorphism or $\phi = 0$.*
2. *When $V = W$, $\phi = \lambda \cdot I$ for some $\lambda \in \mathbb{C}$ with I the identity mapping*

Proof. To prove 1. we note that for $v \in V$ we have $\phi(v) \neq 0$ if $v \neq 0$. So $\text{Im } \phi$ is a non-zero submodule of W and since W is irreducible, it follows $\text{Im } \phi = W$. Furthermore we have $\ker \phi \neq 0$ and by the same argument $\ker \phi = \{0\}$.

As for the second statement, we note \mathbb{C} is algebraically closed so ϕ will have an eigenvalue. In other words, there exist a λ such that $\ker(\phi - \lambda I)$ nonempty. But since ϕ is an isomorphism this implies $\phi = \lambda I$. □

This lemma has a very nice consequence, stated in the following proposition:

Proposition 1.9 (Uniqueness of decomposition). *Given a representation $\rho : G \rightarrow \mathbf{GL}(V)$ of a finite group G there is a decomposition*

$$V = \bigoplus_{i=1}^k V_i^{\oplus a_i} \tag{1.2}$$

where we introduced a common notation of a_i denoting the multiplicities of the irreducible V_i . One may also encounter $V = \sum_{i=1}^k a_i V_i$ or even $a_1 V_1 + \dots + a_k V_k$. where each V_i are invariant submodules corresponding to irreducible subrepresentations. This decomposition is unique in the sense of the invariant submodules V_i and corresponding multiplicities a_i being unique.

Proof. This follows from Schur's Lemma and considering a different representation W with corresponding decomposition $W = \bigoplus_{j=1}^k W_j^{\oplus b_j}$. For a full derivation, see [Fulton and Harris (2005), chapter 1.2]. □

Characters

Having established the main results regarding reducibility and decomposition of representations, we will now define the notion of a character. This notion is a natural way to identify a particular representation and distinguish between equivalent and non-equivalent representations.

Definition 1.10 (Character). Let ρ be a representation of a group G . The *character* of ρ is the set $\{\chi(g) : g \in G\}$ where $\chi(g) = \text{Tr } \rho(g)$. $\chi(g)$ is called the *character of $\rho(g)$* .

An important motivation for this definition is the fact that any two equivalent representations will have the same character, as conjugacy with respect to an element in $\mathbf{GL}(V)$ leaves the trace invariant. By the same logic, characters will identify conjugacy classes as conjugate elements will have the same trace. Furthermore, for a unitary representation $U(g)$ the character will have the property:

$$\chi(g^{-1}) = \text{Tr } (U(g)^{-1}) = \text{Tr } (U(g)^\dagger) = \chi^*(g) \quad (1.3)$$

which is quite a powerful statement in light of Theorem 1.6.

We will now embark upon a journey which will lead us to finding an explicit form of (1.2) using characters. First, we will need a couple of results.

Theorem 1.11 (Fundamental orthogonality theorem). *Let ρ_{jk}^μ be a family of inequivalent irreducible representations of a finite group G (Here μ is an index identifying the representation, jk denotes a matrix element of this representation). Then the following result holds:*

$$\sum_{g \in G} \rho_{jk}^\mu(g) \rho_{rs}^\nu(g^{-1}) = \frac{|G|}{n_\mu} \delta^{\mu\nu} \delta_{js} \delta_{kr} \quad (1.4)$$

where n_μ denotes the number of indices ρ^μ runs through (i.e., its dimension).

Proof. A proof, as obtained from Jones (1998)[Chapter 4.2, pg. 62-63], is given in Appendix B. \square

Corollary 1.12 (Number of irreducible representations). *From the previous theorem, we obtain the following restriction on the number of inequivalent irreducible representations for a finite group G :*

$$\sum_{\mu} n_{\mu}^2 = |G| \quad (1.5)$$

Proof. We will prove the ' \leq ' relation in this equation. Proof of this inequality follows directly from (1.4), as we can (again, in light of Theorem 1.6) restrict ourselves to unitary representations. Now applying $\mu = \nu$ and $\rho_{rs}(g^{-1}) = \rho_{sr}^*(g)$ in (1.4) results in:

$$\sum_{g \in G} \rho_{jk}(g) \rho_{sr}^*(g) = \frac{|G|}{n_\mu} \delta_{js} \delta_{kr}$$

For given j, k the left hand side of this equation is a scalar product in $\mathbb{C}^{|G|}$, with both (ij) and (sr) ranging over 1 to n_μ . In other words, we have an equation regarding n_μ^2 vectors. Now we may range over all possible values of μ to obtain the same equation. The $\delta^{\mu\nu}$ term in (1.4) ensures all of these vectors will be orthogonal, thus we have found $\sum_{\mu} n_{\mu}^2$ orthogonal vectors. As this number cannot exceed the dimension of the group, the inequality is obtained. The direct equality follows from considering characters. \square

We now have treated most material needed to find an explicit form for decompositions. One more result on the orthogonality of characters will be necessary.

Corollary 1.13 (Orthogonality of characters). *Given a family of inequivalent representations ρ^μ with characters $\{\chi(g)\}$ we have:*

$$\frac{1}{|G|} \sum_{g \in G} \chi^\mu(g) \chi^\nu(g^{-1}) = \delta^{\mu\nu} \quad (1.6)$$

Proof. This is a direct application of the fundamental orthogonality theorem, using the definition of a character (thus tracing over appropriate indices in (1.4)) \square

We are now ready to return to the decomposition as in (1.2). As each V_i is an invariant submodule corresponding to some irreducible representation ρ_i acting on V_i , we can write any representation as

$$\rho = \bigoplus_i a_i \rho_i \quad (1.7)$$

where a_i denotes multiplicity of the irreducible ρ_i . From this equation we directly see that for the characters of ρ :

$$\chi(g) = \sum_{\mu} a_{\mu} \rho^{\mu}(g) \quad (1.8)$$

Here $i \rightarrow \mu$ and raising of indices is nothing but relabeling to obtain a familiar form. Multiplying both sides with $\chi^{\mu}(g^{-1})$ and using (1.6) results in:

$$a_{\mu} = \frac{1}{|G|} \sum_{g \in G} \chi(g) \chi^{\mu}(g^{-1}) \quad (1.9)$$

which is the desired explicit expression for multiplicity of irreducible representations. Note that this formula is very similar to a familiar expression of finding coefficients of a vector with respect to a basis if we define the inner product $\langle \chi_1, \chi_2 \rangle = \frac{1}{|G|} \sum_{g \in G} \chi_1(g) \chi_2(g^{-1})$ which indeed has all the properties of an inner product.

1.2.2 Lie Groups

Having obtained some principal results in the field of representation theory, we will now consider an important class of groups - the Lie Groups. Their properties and structure are vital when discussing various symmetries later on. One may assume the results in the previous sections can be extended to the important class of compact Lie Groups, although Lie Groups will not be finite. The following discussion is based mainly on [Kirillov] and [Duistermaat and Kolk (2000)].

Definition 1.14 (Lie Groups). A Lie Group G is a group which is also a finite dimensional real C^∞ -manifold such that

1. The group operation $G \times G \rightarrow G$ is a C^∞ mapping.
2. $\iota : G \rightarrow G$ given by $g \mapsto g^{-1}$ is a C^∞ mapping for $g \in G$

Remark. In the definition of Lie Groups it is often assumed mappings are C^∞ , but one may also encounter a definition which requires a weaker degree of continuity. Throughout this thesis we will assume the former. A *complex Lie group* is easily defined by replacing real with complex in this definition.

Example (The general linear group). By $GL_n(\mathbb{R})$ we denote the set of $n \times n$ invertible matrices/linear mappings with real coefficients. This is a group as the product of invertible matrices will again be invertible. The fact that the group multiplication is differentiable is easy to see using the obvious representation in $\mathbb{R}^{n \times n}$. This group and its complex counterpart are among the most prominent examples we will encounter.

To discuss Lie Groups properly we will introduce a couple of notions. We will not provide an explicit definition as a minimal treatment of the subject is sufficient for our purposes. We will remark that most terminology regarding Lie Groups is referring to either its group structure or its manifold structure without much ambiguity. Abelian, n -dimensional, connectedness are among the non-ambiguous notions when discussing a structure which is both a group and manifold. The notion of a subgroup however, is not so obvious, as we can talk about both a subgroup and a submanifold. A (closed) *Lie subgroup* is usually defined to be a subgroup which is also a (closed) submanifold. Justification for these brackets will follow shortly. There are different (equivalent or slightly different) definitions, one of which we will introduce later on, but this one serves best for our purposes for now.

A *map* between Lie groups is a group homomorphism which is differentiable on its entire image. We also note that there is a very straightforward notion of a *compact* Lie group (that is, a Lie group is compact when the manifold it represents is compact). Compact Lie Groups (that is, Lie Groups which are also compact manifolds) allow for a nice and simple generalization of the results we have shown for finite groups. Essentially one can replace summations by integrals (i.e. $\sum_{g \in G}$ by $\int dg$) due to the differentiable structure we now have on our group, and these are well-behaved for compact groups. We will give an example of how this works in practice in the next subsection.

We will now state and prove some basic but important results in the theory of Lie Groups.

Theorem 1.15 (Closed subgroups are Lie subgroups). *For a Lie group G ;*

1. *Any Lie subgroup is closed*
2. *Any closed subgroup is a Lie subgroup*

Proof. The former can be proven by considering the closure of this subgroup. One can show this is a subgroup, and all of its cosets to be open and dense in H . The latter is beyond the scope of this thesis. There is extensive literature, however, regarding this theorem known as the *Closed subgroup theorem*. To avoid confusion - we should recall that following our definitions earlier, a subgroup will also be a submanifold. \square

Corollary 1.16. *Let G_1, G_2 be Lie groups with the latter being connected. Let U be a neighborhood of the identity element 1 in G_2 and $f_* : T_1G_1 \rightarrow T_1G_2$ (T_1 denoting the tangent space at the identity element) the push-forward of a map $f : G_1 \rightarrow G_2$. We then have:*

1. *U generates G_2*
2. *If f_* is surjective, f will also be surjective*

Proof. 1. U generates a subgroup H . Take any element $h \in H$. We can now form a neighborhood around h by taking the coset hU , so H is open and thus a submanifold. Now by (1.15) it is closed and hence $H = G$, which completes the proof.

2. This is a consequence of the inverse function theorem, from which we can infer there is some neighborhood around 1 for which f is surjective (indeed, any group homomorphism will map identity elements to identity elements). As U generates G_2 , f is surjective. \square

In our discussion on representation theory for finite groups, we encountered conjugacy classes as a very important type of equivalence classes. For Lie groups, we will define equivalence classes in terms of cosets of some appropriate subgroup H .

Theorem 1.17 (Cosets of Lie subgroups are manifolds). *Let G be a Lie Group of dimension n and H be a Lie subgroup of dimension k . Then:*

1. *G/H is a $n - k$ dimensional manifold with tangent space $T_H(G/H) = T_1G/T_1H$. Note that H is the identity element in G/H .*
2. *If H is normal, G/H is a Lie group.*

Proof. See Kirillov, Theorem 2.10 \square

To prove some of the most principal results in Lie group theory we will introduce another definition of a subgroup. This is because we want to distinguish between (a) a subset of our manifold with the structure from this manifold (this is the *(closed) Lie subgroup*) we have already seen and (b) an *immersed Lie subgroup*, i.e. the immersion of a manifold into our Lie subgroup. It is clear the

latter is a more general statement. A very simple example (although not the standard one of a line with irrational slope on the torus) is the following figure which represents a particular immersion (as obtained from [Fulton and Harris (2005), pg. 94]).

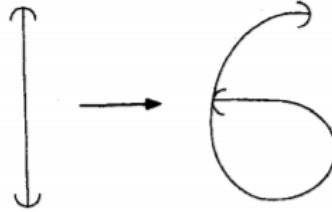

Figure 1.3: An $\mathbb{R} \rightarrow \mathbb{R}^2$ immersion of a line segment

We see the immersion from this line segment in \mathbb{R} into a manifold in \mathbb{R}^2 does not preserve topological structure. We will now introduce a more general definition.

Definition 1.18 (Immersed subgroup). Let G be a Lie group. An *immersed Lie subgroup* is an immersed submanifold which is also a subgroup.

Remark. From now on we will simply use *Lie subgroup* whenever we mean *immersed Lie subgroup*, unless ambiguous.

Introducing this definition allows us to recover a very familiar result in group theory (known as the *first isomorphism theorem*):

Theorem 1.19 (First isomorphism theorem for Lie groups). *Let $f : G_1 \rightarrow G_2$ be a map of Lie groups. Then $\ker f$ is a normal Lie subgroup. Furthermore, $\text{Im} f$ is a Lie subgroup, with f inducing an injective map $G_1 / \ker f \rightarrow \text{Im} f$. The latter is an isomorphism in case $\text{Im} f$ is a submanifold of G_2 . Then $\text{Im} f$ is a closed Lie subgroup.*

Proof. See Kirillov, Corollary 3.30 for a proof. (Note this is a proof based on Lie algebras, a concept we will only touch upon in this thesis.) \square

Having obtained a basis in the theory of Lie groups we are now ready to introduce the concept of an *action*. We encountered this in the previous section (Definition 1.2) but here it will be formally introduced in a more general setting.

Definition 1.20 (Action of a Lie group). Let G be a Lie group and M a manifold. An action of G on M is a function which assigns to each $g \in G$ a diffeomorphism $\rho(g)$ on M , with $\rho(1) = \text{id}$ and $\rho(gh) = \rho(g)\rho(h)$ such that:
 $G \times M \rightarrow M : (g, m) \mapsto \rho(g)(m)$ is smooth.

An obvious example of an action is $\mathbf{GL}_n(\mathbb{R}^n)$ acting on \mathbb{R}^n . The notion of an action gives rise to a "natural" structure for a group to act upon. For example, the group of n -dimensional rotations which leave the origin fixed acts naturally on the sphere S^{n-1} .

One immediately notes there is a special class of actions - the actions of G onto itself. Due to our definition of a Lie group we can easily see the following examples are actions:

Example (Left, right and adjoint action). Given a Lie group G with $g, h \in G$ we subsequently define

1. The *left action* $L_g : G \times G \rightarrow G : g \times h \mapsto gh$ (i.e. $L_g(h) = gh$)
2. The *right action* $R_g : G \times G \rightarrow G : g \times h \mapsto hg$
3. The *adjoint action* $\text{Ad}_g : G \times G \rightarrow G : g \times h \mapsto ghg^{-1}$

We may note that Ad identifies conjugacy classes and in particular Ad_g preserves the identity elements. Therefore Ad_g also defines an action on the vector space T_1G (a vector space we have already encountered in 1.16 and 1.17). In our discussion on representation theory, we let our groups act on vector spaces. We will see that exploring these tangent spaces is helpful in connecting Lie groups and our previous discussion on representation theory. A well-known connection between tangent spaces of manifolds and manifolds themselves is the *exponential map* (in fact, this is a well-known concept from Riemannian geometry), a notion we will look to explore for Lie groups.

First let us define the exponential map for Lie groups. From now on we will call $\mathfrak{g} := T_1G$ to be the *Lie algebra* corresponding to a Lie group G .

Proposition 1.21 (One-parameter subgroups). *Let G be a Lie group and $v \in \mathfrak{g}$. Then there exists a unique map of groups: $\gamma_v : (\mathbb{R}, +) \rightarrow G : t \mapsto \gamma_v(t)$ corresponding to v with $\frac{d}{dt}\gamma_v(0) = v$. γ_v is called the one-parameter subgroup corresponding to v .*

To prove this result, we will need a very useful definition and theorem.

Definition 1.22. A vector field w on G is called left-invariant if $(L_g)_*w = w \quad \forall g \in G$. Similarly, it is right-invariant if $(R_g^{-1})_*w = w \quad \forall g \in G$.

Theorem 1.23. *The map defined by $w \mapsto w(1)$ is an isomorphism between the space of left-invariant vector fields and \mathfrak{g} .*

Proof. We will construct from a given $y \in \mathfrak{g}$ a left-invariant vector field as follows: $y(g) = (L_g)_*y$. It is clear that $y(1) = y$. Furthermore, if we denote the pushforward as a differential (this because the derivation will be more intuitive):

$$\begin{aligned} y(gh) &= (dL_{gh})_1(y) && \text{(i.e. evaluated at the identity)} \\ &= (dL_g \circ dL_h)_1(y) \\ &= (dL_g)_h((dL_h)_1(y)) \\ &= (dL_g)_h(y(h)) \end{aligned}$$

□

Remark. It is clear the same argument can be applied to right-handed vector fields.

Proof of Proposition 1.21. We will prove this for real Lie groups.

Uniqueness - We note that we know in the case of $\gamma : \mathbb{R} \rightarrow \mathbb{R}$, simply $\gamma_v = e^{tv}$ will do. For e^{tv} we have $\frac{d}{dt}e^{tv} = [\dot{\gamma}_v(0) := \frac{d}{dt}e^{tv}|_{t=0}] \cdot e^{tv} = \dot{\gamma}_v(0) \cdot \gamma_v(t) = \gamma_v(t) \cdot \dot{\gamma}_v(0)$. We

can use a variation of this identity by defining (commutativity is, in general not true) $\gamma(t) \cdot \dot{\gamma}(0) = (L_{\gamma(t)})_*(\dot{\gamma}(0))$ and equivalently for multiplication on the right. As such, we are left with a differential equation for γ : $\dot{\gamma}_v(t) = (L_{\gamma(t)})_*(\dot{\gamma}(0))$. So if w is a left-invariant vector field such that $w(1) = v \in \mathfrak{g}$, γ will be its integral curve. This proves uniqueness as left-invariance is not a restriction due to (1.23). *Existence* - Let w be the left-invariant vector field corresponding to v . We will use the notion of *flow*² of our vector field w . Denote $\gamma(t) = \psi^t(1)$. Now this is only well-defined for small enough t as of now (manifolds are locally homeomorphic to Euclidean space). We note:

$$\begin{aligned}\gamma(t+s) &= \psi^{t+s}(1) \\ &= \psi^s(\psi^t(1)) = \psi^s(\gamma(t) \cdot 1) \\ &= \gamma(t) \cdot \psi^s(1) = \gamma(t) \cdot \gamma(s)\end{aligned}$$

The last line is justified as the flow has to be left-invariant when the vector field is. Note that our requirement of t being small also drops due to $\gamma(t+s) = \gamma(t)\gamma(s)$. \square

We can now formally define the exponential map, which will not come as a surprise in light of the preceding proof:

Definition 1.24 (The exponential map). The exponential map: $\exp : \mathfrak{g} \rightarrow G$ is defined to be:

$$\exp(v) = \gamma_v(1) \tag{1.10}$$

Here we used the notation of 1.21.

As follows from the previous discussion this is a well-defined map. We also have the familiar scalar multiplication identity $\gamma_v(\lambda t) = \gamma_{\lambda v}(t)$ as can be easily checked. We will now state a series of useful identities which we will not prove (proofs are easily checked or can be found in Kirillov[Chapter 3.2], amongst others):

Proposition 1.25 (Some useful identities). *Throughout this proposition, $t, s \in \mathbb{K}$ (the relevant scalar field, which was \mathbb{R} so far) and $x, y \in TG$.*

1. *Given a left-invariant vector field w on a Lie group G , the time flow of this vector field is given by $\psi_w^t(g) = g \cdot \exp(tw(1))$ and equivalently for a right-invariant vector field.*
2. $\exp(x) = 1 + x + \frac{1}{2}x^2 + \dots$. *I.e., the familiar Taylor expansion is valid. In particular, $\exp(0) = 1$ and hence $\exp_*(0)$ is the identity map.*
3. $\exp((t+s)x) = \exp(tx)\exp(sx)$
4. *Given a map of groups $\phi : G_1 \rightarrow G_2$, we have $\phi(\exp(x)) = \exp(\phi_*(x))$*

²Formally a flow assigns to a parameter t a diffeomorphism $\psi^t : G \rightarrow G$. The flow of a vector field w is defined to be the value of an integral curve of w on G at time t starting at a point $g \in G$ and can be denoted as $\psi_w^t(g), g \in G$. As it is clear in our discussion we are talking about a flow induced by our vector field w , we drop this subscript.

Theorem 1.26 (G is locally isomorphic to \mathfrak{g}). *Given a Lie group G , the exponential map defines a local diffeomorphism of \mathfrak{g} and G between neighborhoods of 1 in G and 0 in \mathfrak{g} .*

Proof. We will only sketch this proof. Differentiability of \exp is a consequence of the way it has been constructed in 1.21 while invertibility is a consequence of the validity of the Taylor expansion, with differentiability of this inverse being a consequence of the inverse function theorem. \square

The inverse as guaranteed from this Theorem is denoted as \log . From the discussion so far, it is clear that \mathfrak{g} is in fact a very important vector space. Indeed, if we return to 1.16, we see we can in fact generate G from \mathfrak{g} for connected manifolds. Even more so, we know how to construct the required diffeomorphism. Having obtained these results, it is natural to ask which operation in \mathfrak{g} corresponds to the group operation in G . Precisely this question will lead us to the subject of *Lie algebras*. In fact, let's pick $x, y \in \mathfrak{g}$ in a neighborhood of 0 . As \mathfrak{g} and G are locally diffeomorphic there should be a smooth mapping μ such that we can associate the group multiplication $\exp(x) \cdot \exp(y)$ with some $\exp(\mu(x, y))$ with $\mu(x, y) \in \mathfrak{g}$.

Lemma 1.27 (Taylor expansion of μ). *In the notation as above, we have:*

$$\mu(x, y) = x + y + \lambda(x, y) + \dots \quad (1.11)$$

Where higher order terms are of order ≥ 3 and λ is a bilinear antisymmetric mapping.

Proof. As μ is a smooth mapping, it has a Taylor expansion with linear terms in both x and y , quadratic terms in both x and y and a bilinear term $\lambda(x, y)$ and other terms of higher order, which we assume to be negligible. Now setting y or x equal to 0 , noting $\mu(x, 0) = x$ and $\mu(0, y) = y$ we see quadratic terms should drop, while linear terms should just be x and y . So $\mu(x, y) = x + y + \lambda(x, y) + \dots$. Now $\mu(x, x) = 2x = x + x + \lambda(x, x)$, so λ is antisymmetric. \square

We can now define what is known as the *commutator*: $[\cdot, \cdot] : \mathfrak{g} \times \mathfrak{g} \rightarrow \mathfrak{g} : [x, y] = 2\lambda(x, y)$. We will now encounter a series of important results which will help us to form an intuition about what the commutator is.

Proposition 1.28 (Commutator invariance). *We have for a mapping of Lie groups $\phi : G_1 \rightarrow G_2$ the following identity (denoting the Lie Algebra of G_1 by \mathfrak{g}_1):*

$$\phi_*([x, y]) = [\phi_*(x), \phi_*(y)] \quad \forall x, y \in \mathfrak{g}_1 \quad (1.12)$$

Proof. This follows from the fact that ϕ is a diffeomorphism and the last identity in Proposition 1.25. \square

Example (The adjoint operator). If we set $\text{Ad}_g = \phi$ in (Prop. 1.28) we get the identity:

$$[\text{Ad}_g.x, \text{Ad}_g.y] = \text{Ad}_g.[x, y] \quad (1.13)$$

where we denoted $(\text{Ad}_g)_*(x) = \text{Ad}_g.x$. In other words, the commutator is preserved by the adjoint operator.

Before heading any further, we will note an identity, following directly from our definition of the commutator (assuming converge for now):

$$\exp(x)\exp(y) = \exp\left(x + y + \frac{1}{2}[x, y] + \dots\right) \quad (1.14)$$

Successfully applying this identity we find:

$$\exp(x)\exp(y)\exp(-x)\exp(-y) = \exp([x, y] + \dots) \quad (1.15)$$

from which we directly see that for an Abelian group $[x, y]$ has to be zero. So the commutator is an invariant property of conjugacy classes which, in some sense, measures the failing of a group to be commutative.

Example (The general linear group). Let's consider as an example $GL_n(\mathbb{R})$. Expanding the right hand side of (1.15) we get $(1 + x + \dots)(1 + y + \dots)(1 - x + \dots)(1 - y + \dots) = 1 + [x, y]$ from which follows $[x, y] = xy - yx$.

There are a couple of very useful identities we will introduce before heading to a conclusion on this subject. First of all, we note that we can associate each $g \in G$ with an element in $\mathbf{GL}(\mathfrak{g})$ in a diffeomorphic way (as the adjoint operator is a diffeomorphism, as well as the exponential map in a suitable neighborhood). We could in fact, say that this association $\text{Ad} : G \rightarrow \mathbf{GL}(\mathfrak{g})$ defines the operator. As such, the following alternate definition makes sense: $\text{ad} := \text{Ad}_* : \mathfrak{g} \rightarrow \mathfrak{gl}(\mathfrak{g})$. This leads to the identity:

$$\text{ad}(x)(y) = [x, y] \quad (1.16)$$

The proof follows from definition of the adjoint operator in terms of exponential maps.

Theorem 1.29 (Jacobi identity). *A Lie group satisfies the identity:*

$$\text{ad}([x, y]) = \text{ad}(x)\text{ad}(y) - \text{ad}(y)\text{ad}(x) \quad (1.17)$$

Proof. This follows from (1.16), when noting $[x, y] = xy - yx$ in $\mathfrak{gl}(\mathfrak{g})$. But ad should preserve commutator as it is a diffeomorphism, so this identity will also hold in \mathfrak{g} and the result follows. This identity is usually denoted as

$$[x, [y, z]] + [y, [z, x]] + [z, [x, y]] = 0, \quad (1.17b)$$

which is equivalent. □

We have, for now, introduced most of the necessary notions and identities. What will follow is an informal discussion which justifies part of our discussion on conformal symmetry. In notation as in the previous discussion, one can find an explicit expression $\mu(x, y) = x + y + \frac{1}{2}[x, y] + \frac{1}{12}[x, [x, y]] + \dots$ where higher order terms consist of higher-order nesting of commutators in commutators with smaller coefficients. When in a neighborhood of 1, this allows one to recover the group law from the commutator in \mathfrak{g} . We will now introduce one more definition and state an extremely important result.

Definition 1.30 (Lie algebra). A Lie algebra is a vector space \mathfrak{g} with a bilinear anti-symmetric operation $[\cdot, \cdot] : \mathfrak{g} \times \mathfrak{g} \rightarrow \mathfrak{g}$ which satisfies the Jacobi identity (1.17b).

From this definition it becomes clear what the following theorem states:

Theorem 1.31. *For any Lie algebra $(\mathfrak{g}, [,])$ there is a unique simply connected (up to isomorphism) Lie group G with this Lie algebra.*

Proof. We have not gone through enough theory to state the proof of this theorem. However, the literature on this subject is extensive, see for example any of the books Fulton and Harris (2005), Duistermaat and Kolk (2000) and Kirillov. The statement is generally known as Lie's Third Theorem. \square

It is time to conclude this section and evaluate what to take with us. Suppose we want to identify a (connected) symmetry group G which will probably be a subgroup of $GL_n(\mathbb{R})$. We now understand to, in order to do so we can identify conjugacy classes of G , find generators of these and establish Lie brackets. This will completely determine our group structure. Quite powerful indeed.

1.2.3 $SO(3, \mathbb{R})$

We will now consider a common example to illustrate our theory of representations and Lie groups - the special orthogonal group in three dimensions (this terminology will be clear shortly). This is the group of rotations in three dimensions and naturally acts on the sphere S^2 . The fact that this constitutes a group seems natural enough and we will assume it for now.

We will start of by considering what should define a group of rotations. Obviously it should preserve distance to the origin and, in fact, distance between points on the sphere. These considerations lead to the requirement that for $A \in SO(3, \mathbb{R})$ and $x, y \in \mathbb{R}^3$ we have $\langle Ax, Ay \rangle = \langle x, y \rangle$ with $\langle \cdot, \cdot \rangle$ the usual inner product. One can write out this requirement and will see that it equivalent to requiring $A^T A = I$. We now note $\det(A) = \pm 1$. When $\det(A) = -1$, however, we have not preserved our orientation of axis and as such performed an improper rotation. Therefore we define: $SO(3, \mathbb{R}) = \{A \in \mathbb{R}^{3 \times 3} | A^T A = I \text{ and } \det(A) = 1\}$.

Now for our Lie algebra. We want to find generators of $\mathfrak{so}(3, \mathbb{R})$ but do not, a priori, know what this space will look like. We know we can write an element in $SO(3, \mathbb{R})$ as $\exp(x)$ with $x \in \mathfrak{so}(3, \mathbb{R})$. Exploring this we find $A^T A = \exp(\mathfrak{A}^T) \exp(\mathfrak{A}) = (1 + \mathfrak{A}^T + \dots)(1 + \mathfrak{A} + \dots) = (1 + \mathfrak{A}^T + \mathfrak{A} + \mathfrak{A}^T \mathfrak{A})$. Considering this equation up to first order, we have $\mathfrak{A}^T \mathfrak{A} = 0$. Matrices satisfying this equation are antisymmetric. A basis is obtained as follows:

$$\mathfrak{A}_1 = \begin{pmatrix} 0 & 0 & 0 \\ 0 & 0 & -1 \\ 0 & 1 & 0 \end{pmatrix}, \mathfrak{A}_2 = \begin{pmatrix} 0 & -1 & 0 \\ 1 & 0 & 0 \\ 0 & 0 & 0 \end{pmatrix}, \mathfrak{A}_3 = \begin{pmatrix} 0 & 0 & 1 \\ 0 & 0 & 0 \\ -1 & 0 & 0 \end{pmatrix}$$

It is easy to check these span the antisymmetric 3×3 matrices. They can be considered as *infinitesimal generators* for small $\theta_{1,2,3}$, because for instance:

$$I + \theta_1 \mathfrak{A}_1 + \frac{1}{2} \theta_1^2 \mathfrak{A}_1^2 = \begin{pmatrix} 1 & 0 & 0 \\ 0 & 1 - \frac{1}{2} \theta_1^2 & -\theta_1 \\ 0 & \theta_1 & 1 - \frac{1}{2} \theta_1^2 \end{pmatrix}$$

which is precisely the second-order Taylor expansion of

$$\begin{pmatrix} 1 & 0 & 0 \\ 0 & \cos(\theta_1) & -\sin(\theta_1) \\ 0 & \sin(\theta_1) & \cos(\theta_1) \end{pmatrix} = \exp(\theta_1 \mathfrak{A}_1)$$

where the latter identity can easily be verified. One immediately recognizes this matrix as a rotation of an angle θ_1 around the x -axis. The other matrices will give very similar expressions, corresponding to a rotation about the y - and z -axis.

This particular example has a nice Lie algebra, given by $[\mathfrak{A}_1, \mathfrak{A}_2] = \mathfrak{A}_3$, $[\mathfrak{A}_3, \mathfrak{A}_1] = \mathfrak{A}_2$ and $[\mathfrak{A}_2, \mathfrak{A}_3] = \mathfrak{A}_1$. We remark that this relation is precisely of the same nature as the cross-product in \mathbb{R}^3 . In fact, one may define the cross-product in \mathfrak{R}^3 as $v \times w = (v_1^T A_1 + v_2^T A_2 + v_3^T A_3)w$.

The example of $SO(3)$ serves to introduce the important notion of an *adjoint representation*. The adjoint representation of a n -dimensional group is a representation acting on its n -dimensional Lie algebra as a vector space. For $GL_n \mathbb{R}$ for example, we have its Lie algebra all $n \times n$ matrices on which $GL_n \mathbb{R}$ acts by conjugation. In the case of $SO(3, \mathbb{R})$ we have seen we can simply identify an element of \mathbb{R}^3 with an element in the Lie algebra. The actions on \mathbb{R}^3 and $\mathfrak{so}(3, \mathbb{R})$ are equivalent in this way, so the adjoint representation coincides with the irreducible representation given by the group itself acting on \mathbb{R}^3 .

We will now examine a representation of $SO(3, \mathbb{R})$. It is quite natural to simply pick \mathbb{R}^3 as a vector space and let $\rho : SO(3, \mathbb{R}) \times \mathbb{R}^3 \rightarrow \mathbb{R}^3 : g \times v \mapsto gv$. As we have only given formal definitions and proven results for finite groups, it is not immediately clear how to use representation theory in this case. Therefore we will use this continuous group as an example on how to do so. Let's consider an element in $SO(3)$ (we will drop the \mathbb{R} for now) infinitesimally close to the identity. This element, which we will denote by dR is given by $I + \mathfrak{A}_1 + \mathfrak{A}_2 + \mathfrak{A}_3$. Multiplying this with a rotation of θ around the x -axis gives:

$$\begin{aligned} R(\theta)dR &= \begin{pmatrix} 1 & 0 & 0 \\ 0 & \cos(\theta) & -\sin(\theta) \\ 0 & \sin(\theta) & \cos(\theta) \end{pmatrix} \begin{pmatrix} 1 & -\theta_2 & \theta_3 \\ \theta_2 & 1 & -\theta_1 \\ -\theta_3 & \theta_1 & 1 \end{pmatrix} \\ &= \begin{pmatrix} 1 & -\theta_3 & \theta_2 \\ \theta_3 \cos \theta + \theta_2 \sin \theta & \cos \theta - \theta_1 \sin \theta & -\theta_1 \cos \theta - \sin \theta \\ \theta_3 \sin \theta - \theta_2 \cos \theta & \sin \theta - \theta_1 \cos \theta & -\theta_1 \sin \theta + \cos \theta \end{pmatrix} \quad (1.18) \end{aligned}$$

which can be considered to be a volume element around the rotation of an angle θ around the x -axis. Notions of volume element and corresponding density are precisely the ones necessary to replace the $\frac{1}{|g|}$ in Theorem 1.11, amongst others. The subsequent discussion will be valid for any element in $SO(3)$, as equivalence classes are precisely rotations with same angle around different axis, which is clear from geometric arguments.

We will now determine the angle and axis of rotation in (1.18). Note that $\exp(\mathfrak{A}_{1,2,3})$ all are matrices with traces $1 + 2 \cos \theta_{1,2,3}$. In the same way we derive

the angle θ' of $R(\theta)dR$;

$$\begin{aligned} 1 + 2 \cos \theta' &= 1 + 2 \cos \theta - 2\theta_1 \sin \theta \\ \Rightarrow \cos \theta' &= \cos \theta - \theta_1 \sin \theta \\ \Rightarrow \theta' &= \theta + \theta_1 \end{aligned}$$

here the latter identity follows from noting the right hand side is the first-order expansion in θ_1 of $\cos(\theta + \theta_1) = \cos \theta \cos \theta_1 - \sin \theta \sin \theta_1$. We can find an expression for axis of rotation by noting it will be both an eigenvector of $R(\theta)dR$ and $(RdR)^T(RdR)$. We obtain after normalization:

$$n = \left\{ 1, -\frac{1}{2}\theta_3 + \frac{1}{2}\theta_2 \frac{1 + \cos \theta}{\sin \theta}, \frac{1}{2}\theta_2 + \frac{1}{2}\theta_3 \frac{1 + \cos \theta}{\sin \theta} \right\} \quad (1.19)$$

Transforming the neighborhood of the origin (I) to the neighborhood around $R(\theta)dR$ is done by $(n_1\theta', n_2\theta', n_3\theta')$, where $n = (n_1, n_2, n_3)$ from (1.19). The density (of points in $SO(3)$) transformation corresponding to n is given by its Jacobian $J_{ij} = \det \left| \frac{\partial n_i \theta'}{\partial \theta_j} \right|$. Its explicit form is given by:

$$\det J = \det \begin{pmatrix} 1 & 0 & 0 \\ 0 & \theta \frac{1 + \cos \theta}{2 \sin \theta} & -\frac{1}{2}\theta \\ 0 & \frac{1}{2}\theta & \theta \frac{1 + \cos \theta}{2 \sin \theta} \end{pmatrix} = \frac{\theta^2}{2(1 - \cos \theta)} \quad (1.20)$$

which is a function of a similar role as $[g]$ in 1.11, so $\frac{1}{[g]}$ will now correspond to $\omega = \frac{2(1 - \cos \theta)}{\theta^2}$.

In our discussion, we used the fact we can identify each element in $SO(3)$ with a unit axis and scalar corresponding to the rotation performed. As n is a unit vector we can rewrite: $\theta n = (\theta \cos \phi \sin \psi, \theta \sin \phi \sin \psi, \theta \cos \psi)$, the usual representation in polar coordinates. Let Ω denote our parameter space corresponding to the orientation of n (consisting of ϕ , and ψ) with area element $d\Omega$. We may now integrate a function $F(\theta, \Omega)$ over $SO(3)$:

$$\int \int \omega(\theta) F(\theta, \Omega) \theta^2 d\theta d\Omega$$

We can now rewrite our theorem on orthogonality of characters, in the form of 1.13:

$$\int \int 2(1 - \cos \theta) \chi^\mu(\theta) \chi^\nu(\theta) d\theta d\Omega = \delta^{\mu, \nu} \int \int 2(1 - \cos \theta) d\theta d\Omega$$

note that the trace of a rotation matrix is a function of the rotation angle θ only. The integral on the right hand side can explicitly be calculated (θ ranges from 0 to π , ϕ from 0 to 2π and ψ from 0 to π) to be $\delta^{\mu, \nu} \cdot 8\pi$. Integrating out $d\Omega$, we obtain the orthogonality theorem:

$$\frac{1}{\pi} \int \int (1 - \cos \theta) \chi^\mu(\theta) \chi^\nu(\theta) d\theta = \delta^{\mu, \nu} \quad (1.21)$$

For continuous groups, the procedure is usually very similar to this example. One has to introduce some density function (which can very well depend on more

parameters) and integrate over characters. Quite often, one will resort to special properties of the group considered rather than following general steps.

One more remark regarding the use of this particular group. This group is very important in the context of quantum mechanics. Acting with it upon the space of polynomials for it to act on, the 2-dimensional spherical harmonics ('the angular part of' solutions to the Schrödinger equation). It naturally leads to the conservation of $l(l+1)$ as an eigenvalue under rotational symmetry, amongst others.

1.3 Conformal Symmetry

So far we have developed the language to describe a symmetry at the very heart of this thesis - conformal symmetry. Before using this language to be able to describe the group corresponding to conformal symmetry, we will introduce it informally.

In the previous section we have defined what Lie groups and representations of groups are. We have seen that a particular group, $SO(3)$, corresponded to rotational transformations of points around a certain axis. In the same way, we may define the conformal group to be the group of transformations which preserves angle between vectors. We will try to give an intuitive basis for what this would mean by imagining our space to be vectors in two dimensional space starting at the origin. What transformations would leave angles between these vectors invariant? Well, our previous example of the special orthogonal group will definitely do this and should thus be contained in this example of a conformal group. Furthermore, moving our vectors through their embedding space does not change angles. Also, we might rescale our sphere uniformly. In fact, we may even perform rescaling *locally*, i.e. multiply the vectors with a scalar depending on their positions. What is left are the so-called special conformal transformations - inversions of vectors (i.e. $\vec{r} \mapsto \vec{r}/|\vec{r}|^2$) followed by translations and again an inversion. The intuition for this transformation is less obvious. Let us show, however, angles are again preserved here. A vector will be transformed as

$$\vec{r} \mapsto \vec{r}/r^2 + \vec{a} \mapsto \frac{\vec{r}/r^2 + \vec{a}}{(\vec{r}/r^2 + \vec{a}) \cdot (\vec{r}/r^2 + \vec{a})} = \frac{\vec{r} + r^2\vec{a}}{1 + 2\vec{a}\vec{r} + a^2} \quad (1.22)$$

where the latter identity is easily verified. Now if we consider a transformation of two such vectors, \vec{x} and \vec{y} their relative angle will indeed be conserved, as can be checked by (an ugly) computation. These are, in fact, all types of transformations in the conformal group (of this example and in general). For a derivation of the full conformal group, see section 1.3.2.

1.3.1 An example from complex analysis

We will now give a nice example of conformal symmetry arising in the field of complex analysis. Let us look at the functions in the complex domain. First let us formally define what a conformal transformation in this case is.

Definition 1.32 (Directed angle). Let $w, z \in \mathbb{C}$. The *directed angle* from w to z is $\theta \in [0, 2\pi)$ such that $z/|z| = e^{i\theta}w/|w|$.

Using this definition we can define a conformal transformation $f : \mathbb{C} \rightarrow \mathbb{C}$ without ambiguity.

Definition 1.33 (Conformal transformation). A map $f : \mathbb{C} \rightarrow \mathbb{C}$ is a conformal transformation if for any curves $\gamma : [a, b] \rightarrow \mathbb{C}$ and $\gamma_1 : [c, d] \rightarrow \mathbb{C}$ with $\gamma(a) = \gamma(c)$, the directed angle between $\gamma'(a)$ and $\gamma_1'(c)$ is equal to the angle $(f \circ \gamma)'(a)$ and $(f \circ \gamma_1)'(c)$.

Proposition 1.34. Any holomorphic function $f : \mathbb{C} \rightarrow \mathbb{C}$ is a conformal transformation for any z with $f'(z) \neq 0$.

Proof. By computation in notation as in the previous definition:

$$(f \circ \gamma)'(a) = f'(z) \cdot \gamma'(a) \text{ and } (f \circ \gamma_1)'(c) = f'(z)\gamma_1'(c)$$

From which:

$$\frac{(f \circ \gamma)'(a)}{|(f \circ \gamma)'(a)|} / \frac{(f \circ \gamma_1)'(c)}{|(f \circ \gamma_1)'(c)|} = \frac{\gamma'(a)}{|\gamma'(a)|} / \frac{\gamma_1'(c)}{|\gamma_1'(c)|}$$

□

In fact, this connection between holomorphic functions and conformal invariance is one of the reasons conformal symmetry is of great importance in complex analysis. For a discussion which one can follow at the undergraduate level, see [Garrett].

Let us slightly extend this discussion. For more context and elaboration, one can view [Schottenloher (2008)] amongst others.

Definition 1.35. On the extended complex plane $\hat{\mathbb{C}}$, the *Möbius transformations* are the holomorphic functions ϕ given by

$$\begin{pmatrix} a & b \\ c & d \end{pmatrix} \in \text{SL}(2, \mathbb{C})$$

such that $\phi(z) = \frac{a+bz}{c+dz}$. The group operation is given by matrix multiplication. ³

One can show (again, a full derivation beyond our scope) that these transformations are precisely the transformations that exhibit *global conformal invariance* - that is, the property of being injective and holomorphic. This definition makes sense due to Proposition 1.34. It allows us to identify the group of conformal transformations with a compact manifold, in this case the connect component of $\text{SL}(2, \mathbb{C})$, thus $\text{SL}(2, \mathbb{C})/\{\pm 1\}$ which is isomorphic to $\text{SO}(3, 1)$ in \mathbb{R}^{3+1} . This sort of embedding of the conformal group into a compact manifold allows us to use Lie Algebras to define the conformal group, and will be revisited in the next section.

1.3.2 The conformal group

We will now introduce the conformal group in a way familiar to the language of the previous sections. Our discussion on Lie groups ended with the conclusion that in order to determine a Lie group, we solely have to define generators of the Lie algebra and their commutation relations. The fact that conformal transformations form a group is unsurprising. It is not directly clear that it should be a compact manifold, however, a fact we will ignore for now. Let us start with a formal definition.

Definition 1.36 (Conformal equivalence). Let M be a manifold equipped with metrics g, h . These metrics are called *conformally equivalent* if there exists a smooth function $\lambda : M \rightarrow \mathbb{R}$ such that $g(x) = \lambda^2(x)h(x)$ for all $x \in M$.

³The special linear group of dimension 2 in the complex numbers is indeed a group. It is defined by the matrices of determinant 1 and is the normal subgroup of the general linear group.

Note that conformally equivalent metrics form an equivalence class. A manifold equipped with such an equivalence class is called a *conformal manifold*, denoted by $(M, [g])$ (thus a manifold with an equivalence class). We can now also define a *conformal mapping*:

Definition 1.37 (Conformal mapping). Let $(M, [g])$ and $(N, [h])$ be conformal manifolds. A conformal mapping between these manifolds is a smooth mapping $F : M \rightarrow N$ such that:

$$F^*h = \lambda^2 g, \quad (1.23)$$

for a smooth function $\lambda : M \rightarrow \mathbb{R}$.

It may not be clear what is meant by this equation. We recall a metric h on a manifold N is a map taking vector fields X, Y on N to \mathbb{R} . Now $F^*h = h(F_*X, F_*Y)$.

From now on, we will, with an eye on the use of this paragraph in the next chapter work in notation familiar in field theories (i.e. with coordinates x^μ , implicit summation and metrics of the form $g_{\mu\nu}$ etc.). Most of the discussion which follows is still valid or easily generalizable to arbitrary manifolds. However, not adapting this notation would lead us to the undesirable situation in which we would have to repeat our theory multiple times. The discussion that follows is based on Di Francesco (1997). We will start by rewriting 1.23 in coordinates:

$$h_{ij}(F(x^\rho))\partial_\mu F^i(x^\rho)\partial_\nu F^j(x^\rho) = \lambda^2(x^\rho)g_{\mu\nu}(x^\rho) \quad (1.24)$$

We will now look at conformal maps $F : \mathbb{R}^d \supseteq M \rightarrow \mathbb{R}^d$, as vector spaces over the real (or complex, but most results will generalize) numbers will be of our main interest for our conformal maps to act upon. The nice feature of \mathbb{R}^d is its ready-made tangent space. We may simply expand our transformations up to first order (as we have seen before) to find the generators for our Lie algebra. Note that this procedure is justified as long as we are working with infinitesimal transformations and similar to the procedure for $SO(3)$. Expanding $x'^\mu = F(x^\mu)$ and $\lambda(x^\mu)$ in (1.24) up to first order gives:

$$x'^\mu = x^\mu + \epsilon\alpha^\mu \text{ and } \lambda(x^\mu) = 1 + \epsilon f(x^\mu) \quad (1.25)$$

where α^μ is a vector and $f(x^\mu)$ a function. The metric $g_{\mu\nu}$ transforms as:

$$\delta g_{\mu\nu} = -(\partial_\mu \epsilon \alpha_\nu + \partial_\nu \epsilon \alpha_\mu) \quad (1.26)$$

As is clear both intuitively and by explicit first-order expansion. For F to be conformal we should have the proportionality relation:

$$-\delta g_{\mu\nu} = f(x^\rho)g_{\mu\nu} \quad (1.27)$$

The identity follows from $h = g$ in (1.24). We now look to investigate what we can say about this function f . We take the trace of (1.27) to find:

$$f(x^\rho) = \frac{2}{d}\delta_\sigma^\sigma \epsilon^\sigma \quad (1.28)$$

We will now drop the argument of f . We may rewrite (1.27) as $-\delta g_{\mu\nu} = f(x^\rho)g_{\mu\nu} + f(x^\rho)g_{\mu\nu} - f(x^\rho)g_{\mu\nu}$. Substituting (1.26) and applying an extra derivative ∂_ρ gives after relabeling:

$$2\partial_\mu\partial_\nu\epsilon_\mu = \eta_{\mu\rho}\partial_\nu f + \eta_{\nu\rho}\partial_\mu f - \eta_{\mu\nu}\partial_\rho f \quad (1.29)$$

where we assumed our conformal transformation is only infinitesimally different from the standard Minkowski metric $\eta_{\mu\nu} =$. If we subsequently contract with $\eta^{\mu\nu}$ we find:

$$2\partial^2\epsilon_\mu = (2-d)\partial_\mu f$$

we now apply another derivative. Note that the expression obtained will be equal to (1.27) up to two derivatives. We therefore have:

$$(2-d)\partial_\mu\partial_\nu f = \eta_{\mu\nu}\partial^2 f \quad (1.30)$$

which, when contracted with $\eta^{\mu\nu}$ leads to:

$$(d-1)\partial^2 f = 0 \quad (1.31)$$

The case $d = 1$ does not put any constraints on f . And indeed, in one dimension the notion of angles is not present, so we would expect this to be the case. From (1.30) we observe $d = 2$ to be a special case. Let us first consider $d \geq 3$. It is clear from the last two equations that f may only be linear in x^μ , i.e. $f(x^\mu) = A + B_\mu x^\mu$. If we substitute this expression in (1.29) we can infer that ϵ_μ may at most be quadratic in x^μ , i.e. $\epsilon_\mu = a_\mu + b_{\mu\nu}x^\nu + c_{\mu\nu\rho}x^\nu x^\rho$. As we have no constraints on x^μ , we may pick it such that all but one term vanishes and evaluate the equations as obtained in the discussion above. As the a_μ vanishes for any derivative, there are no constraints on this term. It may be clear that a_μ corresponds to (infinitesimal) translations.

Now let us look at the higher order terms. Substituting $f = b_{\mu\nu}x^\nu$ and (once again) (1.26) into (1.27) to obtain:

$$b_{\mu\nu} + b_{\nu\mu} = \frac{2}{d}b_\sigma^\sigma\eta_{\mu\nu} \quad (1.32)$$

As $\eta_{\mu\nu} = 0$ for $\mu \neq \nu$, $b_{\mu\nu}$ will be asymmetric but with nonzero trace. Decomposing it in this way, denoting $m_{\mu\nu}$ to be a traceless antisymmetric matrix we get:

$$b_{\mu\nu} = k\eta_{\mu\nu} + m_{\mu\nu}, \quad (1.33)$$

where the first term corresponds to an infinitesimal scale transformation, and the right hand side (our discussion of $SO(3)$ should ring a bell) an infinitesimal rotation. Now for the last term, which we will substitute in (1.29) we obtain:

$$c_{\mu\nu\rho} = \eta_{\mu\rho}\bar{b}_\nu + \eta_{\mu\nu}\bar{b}_\rho - \eta_{\nu\rho}b_\mu \text{ where } \bar{b} = \frac{1}{d}c_\sigma^\sigma \quad (1.34)$$

The corresponding transformation is of the form:

$$x'^\mu = x^\mu + 2(x_l b^l)x^\mu - b^\mu x^l x_l \quad (1.35)$$

Table 1.2: **Generators of the conformal group**

Transformation	Generator
a_μ	$P_\mu = -i\partial_\mu$
$k\eta_{\mu\nu}$	$D = -ix^\mu\partial_\mu$
$m_{\mu\nu}$	$L_{\mu\nu} = i(x_\mu\partial_\nu - x_\nu\partial_\mu)$
$c_{\mu\nu\rho}$	$K_\mu = -i(2x_\mu x^\nu\partial_\nu - x_\nu x^\nu\partial_\mu)$

corresponding to the expression (1.22). We have now categorized all transformations constituting the conformal group. All that is left is to find the corresponding generators and commutations relations. These are:

where we defined the generators slightly differently and as follows - let ϕ be a state (or element of a vector space, whichever one prefers) on which the group acts. To each infinitesimal transformation $x^\mu \rightarrow x^\mu + \epsilon^\mu$ there is a first-order expansion of some operator O_ϵ such that $\phi(x) \rightarrow \phi(x) + O_\epsilon\phi(x)$ for each transformation. The generators are multiplied by a factor of i to ensure them to be Hermitian. A derivation of the last generator, as this will be least familiar, will be given shortly. We recover the commutation relations $[A, B] = AB - BA$ by letting it act on some arbitrary function in \mathbb{R}^d :

$$[D, P_\mu] = iP_\mu \quad (1.36)$$

$$[D, K_\mu] = -iK_\mu \quad (1.37)$$

$$[K_\mu, P_\nu] = 2i(\eta_{\mu\nu}D - L_{\mu\nu}) \quad (1.38)$$

$$[K_\rho, L_{\mu\nu}] = i(\eta_{\rho\mu}K_\nu - \eta_{\rho\nu}K_\mu) \quad (1.39)$$

$$[P_\rho, L_{\mu\nu}] = i(\eta_{\rho\mu}P_\nu - \eta_{\rho\nu}P_\mu) \quad (1.40)$$

$$[L_{\mu\nu}, L_{\rho\sigma}] = i(\eta_{\nu\rho}L_{\mu\sigma} + \eta_{\mu\sigma}L_{\nu\rho} - \eta_{\mu\rho}L_{\nu\sigma} - \eta_{\nu\sigma}L_{\mu\rho}) \quad (1.41)$$

Note that one may also state other commutation relations, as they can be inferred from one another by the use of 1.29 and direct inspection. These commutation relations will be the final result in this chapter. We have learned that, upon specifying the commutation relations of the generators of its Lie algebra, we have specified the group. In the next chapter we will see the application of this conformal group in physics. Here we will also find representations of our group, referring to the first section of this chapter.

Before ending this section, let us justify the postulation of the Lie Algebra as a definition of the conformal group. We will work in the context of Minkowski space as this is the framework we will usually be working in. However, extensions to other (pseudo) Riemannian metrics are possible.

Definition 1.38 (Conformal compactification). A conformal compactification of a (Lorentzian)⁴ manifold which is non-compact is an embedding of this manifold into a compact manifold as a dense and open subset, such that the embedding is a conformal mapping.

⁴A Lorentzian manifold is a manifold equipped with a metric of the form $\text{diag}(1, -1, \dots, -1)$, i.e. a generalization of \mathbb{R}^{3+1} Minkowski space.

This definition allows us to use our language of Lie Algebras for the conformal group (which is clearly non-compact from the previous definition). One can derive as in [Nikolov-Todorov] the compactification of \mathbb{R}^{n+1} space-time to be the $S^n \times S^1/\{\pm 1\}$.

A derivation of the special conformal generator

Having gone through an entire discussion on Lie groups, we will show how the language of Lie groups and algebras leads to the generator of the special conformal transformation. In spirit of the discussion in 1.21 and onwards, we will start by considering some flow, parametrized by t arounds some $x_0 \in G$. We will show both why the definition of *generator* makes sense in this context and how to apply this to special conformal transformations. We find (locally):

$$\psi^t(x_0) = x_0 + t\psi^1(x_0) + O(t^2)$$

(again we have the property of $\psi^{t+s} = \psi^t \circ \psi^s$ and G being locally homeomorphic to \mathbb{R}^n). Now let us consider a neighborhood of $\mathbf{1}$ in G . We now have the expansion:

$$\psi^t(\mathbf{1}) = \mathbf{1} + t\tilde{G}(\mathbf{1}) + O(t^2)$$

where $\psi^1 := \tilde{G}$. We will show this \tilde{G} to be appropriately named the generator. Defining $\gamma(t) = \psi^t(\mathbf{1})$ as in our discussion leading to the exponential map we see:

$$\frac{d}{dt}\gamma(0) = \left. \frac{d}{dt}\psi^t(\mathbf{1}) \right|_{t=0} = \left. \frac{d}{dt}(\mathbf{1} + t\tilde{G}(\mathbf{1}) + O(t^2)) \right|_{t=0} = \tilde{G}(\mathbf{1})$$

so we see $\tilde{G}(\mathbf{1}) \in \mathfrak{g}$. Furthermore we have:

$$\begin{aligned} \frac{d}{dt}\gamma(t) &= \left. \frac{d}{d\alpha}\gamma(t + \alpha) \right|_{\alpha=0} \\ &= \left. \frac{d}{d\alpha}\phi^{\alpha+t}(\mathbf{1}) \right|_{\alpha=0} \\ &= \left. \frac{d}{d\alpha}\phi^\alpha(\phi^t(\mathbf{1})) \right|_{\alpha=0} \\ &= \left. \frac{d}{d\alpha}(\phi^t(\mathbf{1}) + \alpha\tilde{G}(\phi^t(\mathbf{1})) + O(\alpha^2)) \right|_{\alpha=0} \\ &= \tilde{G}(\phi^t(\mathbf{1})) = \tilde{G}(\gamma(t)) \end{aligned}$$

so we see that the generator, initially an element in the Lie algebra of G will remain the first order expansion of the one-parameter group $\gamma(t)$ as discussed previously. This derivation shows (once again) the power of the discussion on the exponential map and Lie algebras. It allows for a unambiguous definitions of a generator in a connected Lie group. We will now focus on the special conformal transformations. In (1.22) we noted the form of a special conformal transformation to be:

$$\vec{x} \mapsto \frac{\vec{x} - x^2\vec{a}}{1 - 2\vec{a}\vec{x} + a^2}$$

where we applied $\vec{a} \mapsto -\vec{a}$ to arrive at a sign convention as common in literature and in accordance with Table 1.2. Now we introduce a flow corresponding to this transformation:

$$\psi^t(\vec{x}) = \frac{\vec{x} - x^2(t\vec{a})}{1 - 2(t\vec{a}) \cdot \vec{x} + (ta)^2} \quad (1.42)$$

expansion around $t = 0$ gives:

$$\psi^t(\vec{x}) = \vec{x} + t(2(\vec{x} \cdot \vec{a})\vec{x} - x^2\vec{a}) + O(t^2) \quad (1.43)$$

as such, we see $\tilde{G}_{\vec{a}} = 2(\vec{x} \cdot \vec{a})\vec{x} - x^2\vec{a}$. The difference with the notation in Table 1.2 is due to these generators being derived from conformal transformations acting on fields ϕ . Suppose we have some transformation $\vec{x} \mapsto A\vec{x}$ (we will not switch to index notation throughout the derivation, only using vectors and dot products as this prevents a very messy computation. However, vectors may be understood to be space-time coordinates if one pleases) under which the field is transformed as $\phi(\vec{x}) \mapsto \phi'(\vec{x}) = \phi(A^{-1}\vec{x})$. We will now investigate how the field transforms after an infinitesimal special conformal transformations. We have (dropping the \vec{a} subscript):

$$\begin{aligned} \phi(\vec{x}) &\mapsto \phi((\psi^\epsilon(\vec{a}))^{-1}\vec{x}) = \phi((\psi^{-\epsilon}(\vec{a}))\vec{x}) \\ &= \phi(\vec{x} - \epsilon\tilde{G}(\vec{x}) + O(\epsilon^2)) \\ &= \phi(\vec{x}) - \epsilon\tilde{G}(\vec{x}) \cdot \vec{\partial}\phi + O(\epsilon^2)\phi(\vec{x}) \\ &= (\mathbf{1} - \epsilon\tilde{G}(\vec{x}) \cdot \vec{\partial} + O(\epsilon^2))\phi(\vec{x}) \end{aligned} \quad (1.44)$$

which shows $-\tilde{G}(\vec{x}) \cdot \vec{\partial} = -(2(\vec{x} \cdot \vec{a})\vec{x} - x^2\vec{a}) \cdot \vec{\partial}$ is the generator associated with an infinitesimal conformal transformation acting on a field. As the "direction" \vec{a} is arbitrary it is usually not included in the expression. Applying a factor i yields the desired expression in Table 1.2. The other generators for the conformal transformations can be obtained in the exact same way.

Chapter 2

Symmetry Groups in Physics

So far we have given a thorough background on Lie groups and their representations acting on certain manifolds or vector spaces. Defining a group to be a symmetry group, however, required an explicit definition of a certain invariance (in the case of the conformal group relative angles) which translated into a mathematical definition of the group. It is clear that in physical systems *exact* symmetry (the system reducing precisely to itself after a nontrivial transformation) is hardly ever attained. One can, however, work with the notion of symmetries quite well, as we will establish in this chapter.

2.1 Noether's Theorem

It is a remarkable fact that many (partial) differential equations admit a *variational* formalism. That is, one can find the solution to be the function that minimizes a certain functional - i.e. it is the critical point of some *action*:

$$S(\phi) = \int_{\Omega} \mathcal{L}(\omega, \phi, \partial\phi) d\omega$$

with Ω being some domain space. The important feature here is that only first-order derivatives of the function have to be considered. Now suppose we can describe a physical system by such a principle. We will try to see what properties the Lagrangian will satisfy. It is natural to work in the context of field theories, as our discussion on conformal symmetry was also written in language known to field theories. In field theories it is natural to assume we have a Lagrangian *density*, i.e. our action will be of the form:

$$S = \int dt \int d^3x \mathcal{L} \tag{2.1}$$

where the integration variables are evident as we want to consider a theory depending on space-time coordinates. Now as we consider a critical point of S we expect δS to be vanishing in first order. Furthermore we will keep our end points fixed (i.e. $\delta\phi(x, t_1) = \delta\phi(x, t_2)$) if we integrate from t_1 to t_2 . If there is no explicit coordinate dependence of \mathcal{L} (only through the field ϕ , which we take to be a scalar for now), so $\mathcal{L} = \mathcal{L}(\phi, \partial_{\mu}\phi)$ we get (in space-time coordinates $dt d^3x = d^4x$):

$$\begin{aligned}
\delta S &= \int d^4x \left[\frac{\partial \mathcal{L}}{\partial \phi} \delta \phi + \frac{\partial \mathcal{L}}{\partial (\partial_\mu \phi)} \delta (\partial_\mu \phi) \right] \\
&= \int d^4x \left[\left(\frac{\partial \mathcal{L}}{\partial \phi} - \partial_\mu \left(\frac{\partial \mathcal{L}}{\partial (\partial_\mu \phi)} \right) \right) \delta \phi + \partial_\mu \left(\frac{\partial \mathcal{L}}{\partial (\partial_\mu \phi)} \delta \phi \right) \right] \\
&= \int d^4x \left(\frac{\partial \mathcal{L}}{\partial \phi} - \partial_\mu \left(\frac{\partial \mathcal{L}}{\partial (\partial_\mu \phi)} \right) \right) \delta \phi
\end{aligned} \tag{2.2}$$

where the second line is obtained the product rule and noting $\delta(\partial_\mu \phi) = \partial_\mu(\delta\phi)$. The term on the right hand side is a total derivative, which under the imposed constraints together with the assumption of decay at spatial infinity (which is reasonable for any physical field) vanishes due to Stokes when integrated over. We obtain the Euler-Lagrange equation:

$$\frac{\partial \mathcal{L}}{\partial \phi} - \partial_\mu \left(\frac{\partial \mathcal{L}}{\partial (\partial_\mu \phi)} \right) = 0 \tag{2.3}$$

We will stress the significance of this equation by examining the Klein-Gordon¹ equation as an example:

$$\begin{aligned}
\mathcal{L} &= \eta^{\mu\nu} \partial_\mu \partial_\nu \phi - \frac{1}{2} m^2 \phi^2 \\
&= \frac{1}{2} \dot{\phi}^2 - \frac{1}{2} (\nabla \phi)^2 - \frac{1}{2} m^2 \phi^2
\end{aligned} \tag{2.4}$$

If we identify kinetic energy $T = \frac{1}{2} \dot{\phi}^2$ and potential energy $V = (\nabla \phi)^2 + \frac{1}{2} m^2 \phi^2$ as familiar to field theories we have $\mathcal{L} = T - V$ and the Euler-Lagrange equation (2.3) becomes:

$$\partial_\mu \partial^\mu \phi + m^2 \phi = 0$$

Denoting the potential depending on ϕ (thus $\frac{1}{2} m^2 \phi^2$) as $V(\phi)$ we can rewrite this equation as:

$$\partial_\mu \partial^\mu \phi = - \frac{\partial V(\phi)}{\partial \phi} \tag{2.5}$$

which looks quite familiar. In fact, the above statement is true for any $V(\phi)$. We therefore see we can identify the Euler-Lagrange equation as the equation of motion. This is, in fact a general statement if we set $\mathcal{L} = T - V$. Having this Lagrangian formalism, we have a very natural way of talking about a symmetry. It is obvious the Lagrangian for a particular equation of motion is not unique. We may add or multiply by a constant to get the same equations of motion. In fact we could add a term $\partial_\mu F^\mu$, motivated by our derivation of (2.2). Again we vary S while keeping endpoints fixed (i.e. $\delta\phi(t_1, x) = \delta\phi(t_2, x) = 0$ when integrating from t_1 to t_2 .) Following the same procedure as in (2.2) and requiring the original equations of motion to be satisfied (thus we have only a contribution from $\partial_\mu F^\mu$) we obtain:

¹The Klein-Gordon equation is a equation of a quantum (although ϕ here is not defined to be an operator) scalar field, describing massive bosons. Here we have used natural units, thus $c = \hbar = 1$ and are working in Minkowski space, thus $\eta^{\mu\nu} = \text{diag}(1, -1, -1, -1)$

$$\begin{aligned}
\delta S &= \int d^4x \left[\frac{\partial(\partial_\mu F^\mu)}{\partial\phi} \delta\phi + \frac{\partial(\partial_\mu F^\mu)}{\partial(\partial_\mu\phi)} \delta(\partial_\mu\phi) \right] \\
&= \int d^4x \left[\frac{\partial(\partial_\mu F^\mu)}{\partial\phi} \delta\phi + \frac{\partial F^\mu}{\partial\phi} \partial_\mu(\delta\phi) \right] \\
&= \int d^4x \left(\partial_\mu \frac{\partial F^\mu}{\partial\phi} \right) \delta\phi - \left(\partial_\mu \frac{\partial F^\mu}{\partial\phi} \right) \delta\phi + \partial_\mu \left(\frac{\partial F^\mu}{\partial\phi} \delta\phi \right) \\
&= 0
\end{aligned} \tag{2.6}$$

where the last term vanishes due to the same application of Stokes' theorem and our boundary conditions as before. We have shown that the insertion of a total derivative does not change critical points of our functional, and hence the equations of motion indeed are the same in this case. Therefore we can consider Lagrangians to be equivalent when they differ by a total derivative. Indeed this defines an equivalence relation and it makes sense to define the group of transformations which leave the Lagrangian invariant to be the relevant symmetry group of our theory. We will now arrive at a very important theorem known as *Noether's theorem* in the context of symmetry transformations. Let us take a transformation of fields $\delta\phi = X(\phi)$ which gives rise to $\delta\mathcal{L} = \partial_\mu F^\mu(\phi)$. We now get:

$$\begin{aligned}
\delta\mathcal{L} &= \frac{\partial\mathcal{L}}{\partial\phi} \delta\phi + \frac{\partial\mathcal{L}}{\partial(\partial_\mu\phi)} \partial_\mu(\delta\phi) \\
&= \left(\frac{\partial\mathcal{L}}{\partial\phi} - \partial_\mu \frac{\partial\mathcal{L}}{\partial(\partial_\mu\phi)} \right) \delta\phi + \partial_\mu \left(\frac{\partial\mathcal{L}}{\partial(\partial_\mu\phi)} \delta\phi \right) \\
&= \partial_\mu \left(\frac{\partial\mathcal{L}}{\partial(\partial_\mu\phi)} \delta\phi \right)
\end{aligned} \tag{2.7}$$

whenever the equations of motion are satisfied. As we had $\delta\mathcal{L} = \partial_\mu F^\mu(\phi)$, this results in:

$$\partial_\mu j^\mu = 0 \quad \text{where } j^\mu = \frac{\partial\mathcal{L}}{\partial(\partial_\mu\phi)} X(\phi) - F^\mu(\phi) \tag{2.8}$$

This j^μ is called the *Noether current*. With this conserved current we can identify a conserved *charge* Q , as for the time component j^0 we have again using Stokes and the fact that the current is conserved:

$$\frac{d}{dt} \int_{\mathbb{R}^3} d^3x j^0 = \int_{\mathbb{R}^3} -\nabla \cdot \vec{j} \, d^3x = 0 \tag{2.9}$$

which proves we have a conserved charge. A few remarks regarding Noether's theorem:

- Noether's theorem is a statement regarding *continuous* symmetries, as only in that context our derivation makes sense. There is no current corresponding to parity transformation, for example. Note that the infinitesimal character suggests an application of Lie algebras.

- The fact of having a conserved current is a much stronger statement than having a conserved charge, as the former is local in nature, thus holds everywhere in space-time.
- Our derivation is constructive, i.e. it gives an explicit formula for conserved charge and conserved current. If we consider for example infinitesimal time and spatial transformations, we get conserved energy and momentum. See for a derivation Tong[Chapter 1.3].
- If we consider the formulation of quantum mechanics, any operator A commuting with the Hamiltonian gives rise to a symmetry with conserved A itself.

2.1.1 The Energy Momentum Tensor

In (2.8) we obtained an explicit general expression for the conserved current j^μ . Let us now briefly consider the case of an infinitesimal translation. In this case (see [Tong, Chapter 1] for a reference), we have:

$$(j^\mu)_\nu = \frac{\partial \mathcal{L}}{\partial(\partial_\mu \phi)} \partial_\nu - \delta_\nu^\mu \mathcal{L} \quad (2.10)$$

known as the *Canonical Energy Momentum Tensor* (CEMT), which we will denote by $t^{\mu\nu}$. Here μ labels entries of the current, while ν labels the translations in spacetime. One can from this tensor construct a symmetric energy momentum tensor (SEMT):

$$T^{\mu\nu} = t^{\mu\nu} - \frac{1}{2} \partial_\rho \Gamma^{\rho\mu\nu} \quad (2.11)$$

where $\Gamma^{\rho\mu\nu}$ is required to be antisymmetric in the first two indices such that this new tensor will be conserved. One can construct the tensor Γ from what is known as the *Spin tensor* (see [Weinberg (1995a)] amongst others for a reference). We will for now not concern ourselves with the precise restrictions for the symmetric tensor to exist. One can show, however (as done in [Tong, Chapter 1] amongst others), that the conserved tensor for infinitesimal rotations is given by (up to a spin tensor):

$$L^{\mu\nu\rho} = x^\mu T^{\nu\rho} - x^\nu T^{\mu\rho} \quad (2.12)$$

Comparing the relation between these tensors with the generators of the conformal group in Table 1.2 we see there is a direct relation between generators and corresponding conserved tensors, a relation we will seek to explore when discussing the Goldstone modes for the conformal group in Chapter 4.

2.2 Symmetry breaking

In the remainder of this thesis, we will encounter various forms of the notion of symmetry breaking. We will now explore terminology of various symmetries and symmetry breaking. From now on, we will define and explore operators in terms of commutator brackets. The relevant physical theories discussed admit a notation in terms of Lagrangians \mathcal{L} or Hamiltonian \mathcal{H} which define the mechanics

of our theory. We can define the terminology in either one, but will opt to define it in terms of the Lagrangian, as this is the formalism already introduced in the previous sections.

Exact symmetry This kind of symmetry is obtained for some operator \mathcal{A} when the commutator $[\mathcal{L}, \mathcal{A}] = 0$. Physically, this means there is no difference in establishing the Lagrangian and acting with the operator on it or acting with the operator on a state and then acting with the Lagrangian operator. An obvious example is a rotation for an angular symmetric Lagrangian. It is clear there is invariance of equations of motion upon such transformations.

Explicit symmetry breaking An explicit symmetry breaking is an operator transformation such that $[\mathcal{A}, \mathcal{L}] \neq 0$. Now consider for an example $\mathcal{L} \rightarrow \mathcal{L} + \mathcal{L}_2$ with \mathcal{L} the Lagrangian of an electron in a hydrogen atom, which will be rotationally symmetric. Introducing an external magnetic field and corresponding Lagrangian term \mathcal{L}_2 with $[\mathcal{A}, \mathcal{L}_2] \neq 0$ if \mathcal{A} is a rotation.

Spontaneous symmetry breaking This form of symmetry breaking is characterized by a Lagrangian which exhibits a symmetry, i.e. $[\mathcal{A}, \mathcal{L}] = 0$ for some symmetry transformation \mathcal{A} , but the ground state of the system (indeed, the ground state has to be defined for a mathematical structure on which the transformation acts but is often clear in the context of physical systems) does not have this symmetry. We can for an example turn to ferromagnetism. In a ferromagnetic material, spins align randomly and thus any macroscopic quantity such as magnetization will vanish and be rotationally symmetric. In particular, the ground state will be disorder and thus have an expectation value for magnetization in the ground state will be zero. Now if we lower the temperature under a certain temperature T_C (the Curie temperature) the ground state of the system will be to completely align. The direction of alignment is random (i.e. the Lagrangian has rotational symmetry), however, the expectation value of magnetization is different than before lowering of temperature.

Anomalous symmetry breaking Anomalous symmetry breaking is symmetry breaking due to the appearance of quantum effects, i.e. a symmetry broken at the quantum level.

2.3 The Goldstone Theorem

We will now introduce the celebrated Goldstone Theorem, which relates spontaneous symmetry breaking and the existence of a certain type of bosons in the context of quantum field theory. There are multiple ways to arrive at equivalent forms of this theorem. we will investigate two forms, as both of these are frequently used in literature and translating from one to the other is not always obvious or practical.

2.3.1 On spontaneous symmetry breaking

Before we start proving the Goldstone Theorem, let us consider a field ϕ and some potential $V(\phi)$

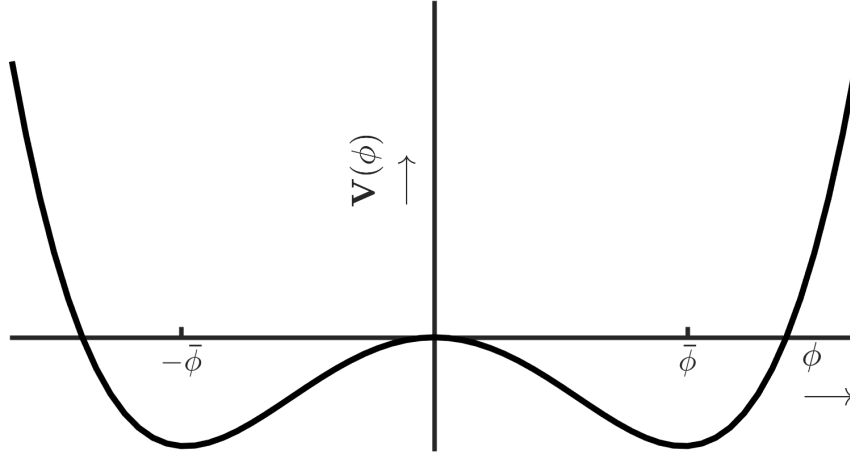

Figure 2.1: A potential symmetric under $\phi \mapsto -\phi$

which is of the form $V(\phi) = \mu^2\phi^2 + \lambda^2\phi^4$ with μ imaginary and λ real. Obviously, this potential is symmetric under $\phi \mapsto P_-\phi = -\phi$ and we may also expect $[P_-, \mathcal{L}] = 0$. The vacua, $\bar{\phi}$ and $-\bar{\phi}$ however, are not invariant under this transformation and thus we have an example of (discrete) spontaneous symmetry breaking. We should be careful, however, to assume that these are indeed the vacua. Although these fields indeed minimize the potential, we cannot a priori exclude $\frac{1}{\sqrt{2}}(|\bar{\phi}\rangle + |-\bar{\phi}\rangle)$ for instance, a state which is clearly symmetric under the operator P_- and thus resulting in no spontaneous symmetry breaking. We will discuss this issue shortly as it will give us a more thorough understanding on the Goldstone Theorem and introduces some notation we will use later on. Assuming $[\mathcal{H}, P_-] = 0$ implies:

$$\begin{aligned}\langle -\bar{\phi} | \mathcal{H} | -\bar{\phi} \rangle &= \langle \bar{\phi} | \mathcal{H} | \bar{\phi} \rangle = a \\ \langle \bar{\phi} | \mathcal{H} | -\bar{\phi} \rangle &= \langle -\bar{\phi} | \mathcal{H} | \bar{\phi} \rangle = b\end{aligned}$$

with a and b real numbers. This implies $|\bar{\phi}\rangle \pm |-\bar{\phi}\rangle$ to be eigenstates of the Hamiltonian with energies $a \pm |b|$. The a has the interpretation of the energy of the system in a minimum of the potential and b corresponds to a tunneling term from $|\bar{\phi}\rangle$ to $|-\bar{\phi}\rangle$. It is proportional to some tunneling factor of the form $\exp(-CV)$ with V being the characteristic volume involved and thus will be very small for any macroscopic volume. Therefore $|\bar{\phi}\rangle \pm |-\bar{\phi}\rangle$ will be essentially degenerate (as their energy difference is very small). If we introduce a small perturbation \mathcal{H}' as in the following figure, these states will therefore be strongly mixed. Much stronger, in fact, than the ground states $|\pm\bar{\phi}\rangle$. We conclude vacuum eigenstates of the Hamiltonian will be very close to the latter states. And for sufficiently small perturbation (the states are related by a transformation leaving the original

Hamiltonian invariant) we will not be able to tell which is the "true" vacuum state. This reasoning justifies viewing perturbations as breaking the symmetry of a system. A formal exploration of this reasoning is given in [Weinberg (1995b), Chapter 19].

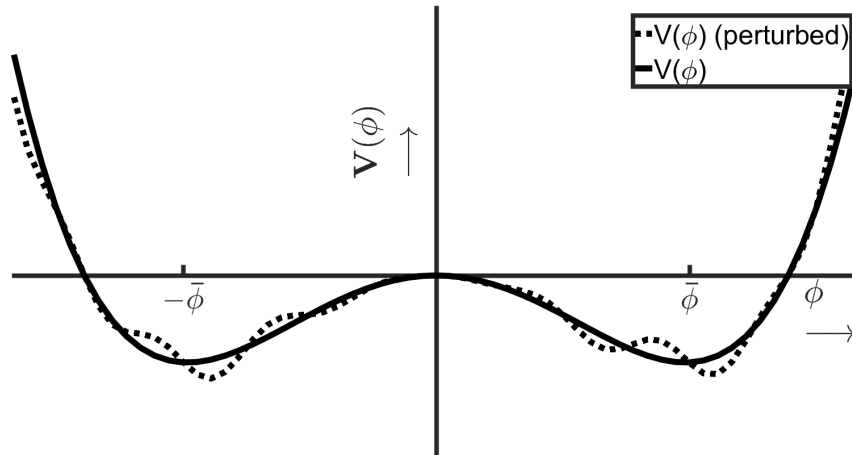

Figure 2.2: A potential symmetric under $\phi \mapsto -\phi$ with small perturbation

2.3.2 Effective action formalism

Let us consider a proof for the existence of Goldstone bosons in terms of the *action*, a concept we already encountered in a previous section. We will be working in the context of a relativistic field theory, while considering internal symmetries (thus acting on the fields, not the coordinates). If we continuously transform some scalar field $\phi \rightarrow \phi'$ such that the action is preserved, i.e. $\delta S = 0$, we have a notion of symmetry equivalent to one in Section 2.2. Now in quantum mechanics, there is no well-defined path and dynamics and the correct notion is the *effective* action, taking into account the quantum effects corresponding to amplitudes of various paths. For an in-depth discussion on this effective action $\Gamma[\phi]$ and associated effective potential $V(\phi)$, see for instance the volumes of Weinberg (1995b).

We will consider a set of labeled scalar fields ϕ_n with corresponding Hermitian operators $\hat{\phi}_n$ and a linear infinitesimal transformation ² as follows:

$$\phi_n(x) \rightarrow \phi_n(x) + i\epsilon \sum_m t_{nm} \phi_m(x) \quad (2.13)$$

with t_{nm} purely imaginary to make it Hermitian. We had $\delta S = 0$ as a notion of our symmetry. One can show that together with the metric being invariant the effective action S_{eff} will also be invariant (a calculation beyond the scope of

²For infinitesimal transformations, the assumption of the transformation being linear is not a restriction as higher-order terms will vanish in a Taylor expansion

this thesis), i.e.:

$$\sum_{n,m} \int \frac{\delta S_{\text{eff}}}{\delta \phi_n(x)} t_{nm} \phi_m(x) d^4x = 0 \quad (2.14)$$

Imposing translational invariance, this requirement translates to a requirement in terms of the potential as follows (again see [Weinberg (1995b), Chapter 16] for a detailed explanation):

$$\sum_n \frac{\partial V(\phi)}{\partial \phi_n} t_{nl} + \sum_{n,m} \frac{\partial^2 V(\phi)}{\partial \phi_n \partial \phi_l} t_{nm} \phi_m = 0 \quad (2.15)$$

Now let us consider $\phi_n = \bar{\phi}_n$ such that $V(\phi)$ is minimal, thus $\bar{\phi}_n$ being the vacuum. Here $\left. \frac{\partial V(\phi)}{\partial \phi_n} \right|_{\phi=\bar{\phi}}$ vanishes up to first order and we may conclude:

$$\sum_{n,m} \left. \frac{\partial^2 V(\phi)}{\partial \phi_n \partial \phi_l} \right|_{\phi=\bar{\phi}} t_{nm} \bar{\phi}_m = 0 \quad (2.16)$$

Now if a symmetry is broken, meaning $t_{nm} \bar{\phi}_m$ is non-vanishing it must be an eigenvector of this $\left. \frac{\partial^2 V(\phi)}{\partial \phi_n \partial \phi_l} \right|_{\phi=\bar{\phi}}$ with eigenvalue zero and we identify $t_{nm} \bar{\phi}_m$ to be a massless Goldstone boson. This boson being massless follows from the usual interpretation of $\left. \frac{\partial^2 V(\phi)}{\partial \phi_n \partial \phi_l} \right|_{\phi=\bar{\phi}}$ as the mass matrix, being very close to diagonal following our previous discussion. We conclude that for all generators of the symmetry which are linearly independent we find a massless Goldstone boson $t\bar{\phi}$.

Let us illustrate the interpretation of this boson as a massless boson by considering a Lagrangian of the following familiar form:

$$\mathcal{L} = -\frac{1}{2} \sum_n \partial_\mu \phi_n \partial^\mu \phi_n - \frac{\mathcal{M}^2}{2} \sum_n \phi_n \phi_n - \frac{g}{4} (\sum_n \phi_n \phi_n)^2 \quad (2.17)$$

we note that the potential (with usual interpretation of $\mathcal{L} = T - V$) in this Lagrangian is precisely the n -dimensional form of the potential in 2.1 in case \mathcal{M}^2 negative and g positive. Note that we can view this to be a perturbation of the "standard" Lagrangian, with a perturbation term $\propto g$. So we have $V(\phi) = \frac{\mathcal{M}^2}{2} \sum_n \phi_n \phi_n + \frac{g}{4} (\sum_n \phi_n \phi_n)^2$.

As in our previous discussion, we will look at minima of this potential. If g is positive (and only then our interpretation of it as a perturbation makes sense) we have minima $\bar{\phi} = 0$ which is not of great interest to us here, and a minimum given by:

$$\sum_n \bar{\phi}_n \bar{\phi}_n = -\frac{\mathcal{M}^2}{g} \quad (2.18)$$

we obtain a mass matrix

$$\begin{aligned} M_{mn} &= \left. \frac{\partial^2 V(\phi)}{\partial \phi_n \partial \phi_m} \right|_{\phi=\bar{\phi}} \\ &= \mathcal{M}^2 \delta_{mn} + g \delta_{mn} \sum_k \bar{\phi}_k \bar{\phi}_k + 2g \bar{\phi}_n \bar{\phi}_m \\ &= 2g \bar{\phi}_n \bar{\phi}_m \end{aligned} \quad (2.19)$$

where the last equality follows directly from inserting (2.18). A diagonal mass matrix implies the latter has one eigenvector $\bar{\phi}_n$ with eigenvalue $m^2 = 2g \sum_n \bar{\phi}_n \bar{\phi}_n$. Suppose the number of scalar fields was N , then there are $N - 1$ fields $\bar{\phi}_{m \neq n}$ with eigenvalue zero - the Goldstone bosons. The reason why there should be $N - 1$ of these is that the relevant symmetry group, $O(N)$ is broken down to a $O(N - 1)$ symmetry group leaving $\bar{\phi}$ invariant, as we had one eigenvector with eigenvalue nonzero, and $\dim(O(N)) - \dim(O(N - 1)) = N - 1$.

It is time to recap on what we have (and maybe more importantly) haven't done. We have shown that for a continuous global internal symmetry (our t_{mn} were not coordinate-dependent) we have a well-defined set of vacua and for each generator of a spontaneous symmetry breaking there is an associated massless Goldstone boson. More formally, if we have a symmetry group G of our Hamiltonian of which a subgroup H leaves the vacua invariant, there are $\dim G - \dim H$ associated Goldstone bosons. We should strongly emphasize that our discussion was in the framework of Quantum Field Theory, and thus no conclusion about a non-relativistic case can be given. Furthermore, we might suspect a similar derivation to hold for spacetime symmetries rather than internal ones, but how this should hold exactly is to be investigated. In particular, we want to discuss the conformal symmetry group.

Chapter 3

Nambu-Goldstone bosons: a review

The theory we have discussed is not easily generalizable to any transformation in the sense that the statement "For any symmetry transformation there is a Goldstone mode" is not true. A clear example arises when discussing the Heisenberg model for ferromagnets and antiferromagnets.¹ It is known that for a ferromagnet the number of broken generators (2, corresponding to rotations in 3-dimensional space) give rise to only one Goldstone boson, whereas in the case of the antiferromagnet there are two distinct Goldstone modes. For a discussion which does not assume a readily developed theory of Goldstone bosons, see [Fjaerestad] amongst others.

The correct counting of the number of (Nambu-)Goldstone bosons (n_{NG}) corresponding to the number of broken generators (n_{BG}) was first developed in a paper by H.B. Nielsen and S. Chadha [Nielsen and Chadha (1976)] which considers theories which are not Lorentz invariant and gives several inequalities. Generalizations, giving conditions for which equalities rather than inequalities hold were developed fairly recently in [Schäfer (2001)], [Watanabe and Brauner (2011)] and [Watanabe and Murayama]. A discussion on spontaneously broken spacetime symmetries can be found in [Low and Manohar], while the case of broken translational invariance is investigated in [Watanabe and Brauner].

In this chapter, we will start by considering a broader discussion of symmetries which should help to clarify the terminology in the to be reviewed papers in section 3.1.1. In 3.1.2, we will re-establish Goldstone's theorem in the same context as the previous section, thus for relativistic internal symmetries. In 3.1.3 we will review papers establishing the counting of Goldstone bosons in non-relativistic setting. In section 3.2 we will switch to the discussion of space-time symmetries, naturally leading to a discussion of conformal symmetry in Chapter 4.

¹The antiferromagnet is a form of magnetism in which spins align opposite to those of their neighbours at lower temperatures

3.1 Nambu-Goldstone bosons in (non)relativistic theories

The discussion presented in this section follows subsequently the initial theorems by Nielsen and Chadha in their 1976 paper while also following papers of Schäfer et al., Watanabe and Brauner and Watanabe and Murayama to establish a contemporary understanding of the number of Nambu-Goldstone bosons. We start by reviewing what is a more common version of the Goldstone theorem than the one given in section 2.3.2. We will start by formulating our assumptions and discussing them, after which we will prove the Goldstone theorem in this new setting. Up to now, we have proven Noether's theorem for a reasonably well-defined notion of symmetry. We will now consider a quantized field theory for which we will first introduce some preliminaries. This is necessary to understand what the specific context is of the Goldstone theorem.

3.1.1 Symmetry transformations and operators

We will start with a quantized field theory with states $|\phi\rangle$ living in a Hilbert space. From Noether's Theorem we have established that for a Lie symmetry group G leaving the action invariant one has a conserved current j^μ and corresponding conserved charge Q , given by the space integral of this current. We will now proceed to associate this charge with the transformation itself.

In quantum mechanics, one can establish another notion of a symmetry transformation $f : |\phi\rangle \rightarrow |\phi'\rangle$ to be a transformation which preserves inner products (interpreted as transition probabilities), i.e. $|\langle\phi|\psi\rangle| = |\langle\phi'|\psi'\rangle|$. It has been shown (see [Griffiths (2005)], amongst others) that these symmetry transformations are those generated by linear and unitary operators. In order to unify both of these natural notions of a symmetry transformation, one thus needs to have a linear and unitary operator leaving the action invariant, i.e. $\delta S = 0$. Now let us consider the charge operator \hat{Q} of an internal symmetry with corresponding unitary operator $\hat{U} = \exp(i\eta\hat{Q})$, of which the significance will become clear shortly.

Theorem 3.1 (Fabri-Picasso). *Following the discussion above (thus \hat{Q} being a charge operator induced by an internal symmetry transformation of the action) and a translationally invariant vacuum state $|0\rangle$, the following cases exhaust the possibilities:*

1. $\hat{Q}|0\rangle = 0$, thus $|0\rangle$ is an eigenstate of this operator with eigenvalue 0.
2. There is no element in the Hilbert space corresponding to $\hat{Q}|0\rangle$, i.e. $|\hat{Q}|0\rangle| = \infty$.

Proof. Naturally, our internal symmetry will commute with \hat{P}^μ , the four-momentum operators. This, and translational invariance of the vacuum results in:

$$\langle 0|J^0(\mathbf{x})\hat{Q}|0\rangle = \langle 0|e^{i\hat{P}\cdot x}J^0(0)\hat{Q}e^{-i\hat{P}\cdot x}|0\rangle = \langle 0|J^0(0)\hat{Q}|0\rangle \quad (3.1)$$

where we denoted J^μ to be the operator corresponding to the current j^μ . We are now ready to evaluate the norm of $\hat{Q}|0\rangle$:

$$\langle 0|\hat{Q}\hat{Q}|0\rangle = \int_V d^3x \langle 0|J^0(\mathbf{x})\hat{Q}|0\rangle = \int_V d^3x \langle 0|J^0(0)\hat{Q}|0\rangle \quad (3.2)$$

which is divergent as $V \rightarrow \infty$ and thus there cannot be a unitary transformation between the states $|0\rangle$ and $\hat{Q}|0\rangle$. \square

It is clear that the former case is one of exact symmetry, and the latter strongly hints at spontaneous symmetry breaking. Often, the latter statement is (somewhat imprecisely, as we will see in this section) denoted by $\hat{Q}|0\rangle \neq 0$.

We will now examine the validity of charges being generators of symmetry transformations. First, let us consider an element g of our symmetry group, which is represented as a unitary operator acting by conjugation on states by $g \mapsto T_g = \exp(tX)$ with t an (infinitesimal) parameter and X the corresponding parameter. In language familiar to us, we expand to find:

$$(g|\phi\rangle)(y) = \exp(-tX)|\phi\rangle(y)\exp(tX) = (1 + [X, \cdot] + O(t^2))|\phi\rangle(y)$$

if we want this equation to have the form $g|\phi\rangle(y) = (1 + t\frac{\delta\phi}{\delta t}(y) + O(t^2))|\phi(y)\rangle$ we should have

$$[X, \phi] = \frac{\delta\phi}{\delta t} \quad (3.3)$$

Now let us consider how the charge commutes with ϕ . We will examine a simplified example of a (charged) scalar field ϕ with action $S = \int d^4x \partial_\mu \phi \partial^\mu \phi^*$ with corresponding canonical momenta $\pi = \frac{\partial \mathcal{L}}{\partial(\partial_\mu \phi)}$ and $\pi^* = \frac{\partial \mathcal{L}}{\partial(\partial_\mu \phi^*)}$. From (2.8) we have:

$$j^\mu = \pi(x)\delta\phi(x) + \pi^*(x)\delta\phi^*(x)$$

so

$$Q = \int d^3x j^0(x) = \int d^3x [\pi(x)\delta\phi(x) + \pi^*(x)\delta\phi^*(x)]$$

and it follows from the general commutator relations (see Appendix B):

$$[Q, \phi(x)] = -i\delta\phi(x) \quad (3.4)$$

which in first order differs from (3.3) by a factor of $-i$, which ensures a Hermitian transformation and corresponding unitary $\exp(tX)$. For a more general proof, see Weinberg (1995a)[Chapter 7].

In fact, the "converse" is also true:

Theorem 3.2 (Coleman's Theorem). *Let G be a symmetry group and Q_α be the generators of this symmetry group. If $Q_\alpha = \int d^3x j_\alpha^0(\vec{x}, t)$ for some (not necessarily conserved) current j^0 and Q_α annihilates the vacuum, the Hamiltonian of the system will be invariant under G and j^μ will be conserved.*

Proof. We have:

$$Q_\alpha(t)|0\rangle = \int d^3x j_\alpha^0(\vec{x}, t)|0\rangle = 0$$

Considering a state $\langle n|$ with vanishing 3-momentum, one has:

$$\langle n| \int d^3x j_\alpha^0(\vec{x}, t) |0\rangle = \int d^3x \langle n| j_\alpha^0(\vec{x}, t) |0\rangle = 0$$

and from the requirement of 3-momentum to vanish corresponding to translational invariance we establish:

$$\langle n| j_\alpha^0(\vec{x}, t) |0\rangle = 0$$

from which follows:

$$\langle n| \partial_\mu j_\alpha^\mu(\vec{x}, t) |0\rangle = 0.$$

For Lorentz invariant systems, this equation will hold in any reference frame and thus also be valid for non-vanishing 3-momentum states and thus we have $\partial_\mu j^\mu = 0$. We conclude $Q_\alpha(t)$ to be independent of time and therefore:

$$\frac{dQ_\alpha}{dt} = i[Q_\alpha, \mathcal{H}] = 0 \quad (3.5)$$

which proves the theorem. \square

So far so good. We have established charges as the generators of symmetry transformations for exact symmetries. But for the case of spontaneously broken symmetries we found $|Q_\alpha |0\rangle| = \infty$ and we can not view them as the generators of our unitary group. Indeed, if we have a charge corresponding to a spontaneously broken symmetry it does not generate the symmetry transformation and the states in this system will not transform as an irreducible transformation.

3.1.2 The Goldstone Theorem for internal symmetries

Let us consider a conserved current $j^\mu(x)$ (with $x = (\vec{x}, t)$). We will define an operator:

$$Q_V(t) = \int_V d^3\vec{x} j^0(\vec{x}, t) \quad (3.6)$$

in some volume V we are considering and redefine the condition for spontaneous symmetry breaking to be:

$$\lim_{V \rightarrow \infty} \langle 0|[Q_V(t), \phi]|0\rangle \neq 0 \quad (3.7)$$

Again, we will assume $|0\rangle$ to be the translationally invariant vacuum. The $Q_V(t)$ is known as a broken charge when this equation holds. It is clear this definition of spontaneous symmetry breaking implies a non-vanishing vacuum expectation value $Q_V(t) |0\rangle$. This observation and the notion of a spontaneous symmetry breaking to be one which does not leave the ground state intact suggests the existence of a degenerate vacuum state generated by this charge operator - in the case of a continuous transformation, one expects infinitely many of these.

Let us restate this in a more formal way. As the operator $Q_V(t)$ has finite norm, it induces a finite symmetry transformation $U_V(\theta, t) = \exp(i\theta Q_V(t))$ giving a "rotated" ground state $|\theta, t\rangle_V = U_V^\dagger(\theta, t)|0\rangle$. Now defining the operator $Q(t) =$

$\lim_{V \rightarrow \infty} Q_V(t)$ and corresponding $U(\theta, t) = \exp(i\theta Q(t))$ seems logical but fails due to Theorem 3.1. What can be proven is:

$$\lim_{V \rightarrow \infty} \langle 0 | \theta, t \rangle_V = \lim_{V \rightarrow \infty} \langle 0 | \exp(-i\theta Q_V(t)) | \theta, t \rangle_V \quad (3.8)$$

showing that the vacuum states are orthogonal to each other. The same holds for excited states and therefore (in the case of continuous transformations) there is no separable Hilbert space to store all these vacuum states. Physical observables, however, are unaffected in the sense that they can unambiguously defined in the following sense. Let A be an operator. We find (for a justification of this expression, see Prop. 1.28 and onwards):

$$A_{\theta, t; V} := U_V(\theta, t) A U_V^\dagger(\theta, t) = A + i\theta [Q_V(t), A] + \frac{(i\theta)^2}{2} [Q_V(t), [Q_V(t), A]] + \dots \quad (3.9)$$

where we defined $[Q_V(t), A] = \int d^3x [j^0(x), A]$. If our operator A is nonvanishing in a finite domain, this expression will be finite and thus $A_{\theta, t; V}$ will have a well-defined limit and allows us to connect expectation values of A in $|\theta, t\rangle_V$ and $A_{\theta, t; V}$ in $|0\rangle$.

Let us now state and prove Goldstone's theorem. We assume the following:

1. The (degenerate) vacuum is invariant under a subgroup F of the symmetry group G of the Hamiltonian
2. Our theory is Lorentz covariant

Theorem 3.3 (Goldstone's Theorem, relativistic case). *In the notation and terminology of the previous section, if a symmetry generated by a charge (labeled as there may be a multiple) $Q^\alpha = \int d^3x j^{0, \alpha}$, thus $\lim_{V \rightarrow \infty} [Q^\alpha, H] = 0$ and spontaneously broken in the sense of (3.7) with operator A (non-vanishing for a finite region), there is a massless mode in the energy spectrum.*

Following our assumptions we have;

$$\lim_{V \rightarrow \infty} \left[\frac{d}{dt} Q_V(t), A \right] = 0 \quad (3.10)$$

In fact, we have the stronger statement to hold:

$$0 = \int_V d^3\vec{x} [\partial_\mu j^\mu(\vec{x}, t), A] = \frac{d}{dt} \int_V d^3 [j^0(\vec{x}, t), A] + \int_S d\vec{S} \cdot [j^0(\vec{x}, t), A] \quad (3.11)$$

with S the surface corresponding to the volume V we are considering. Now in the spirit of our derivation in terms of an effective action, we may expect the last commutator to vanish for very large space-like intervals. Therefore the quantity $\int_V d^3\vec{x} [j^0(\vec{x}, t), A]$ is conserved as well as the corresponding charge. Now let us consider a set $\phi_i(x)$ of local operators not invariant under a continuous symmetry generated by Q^α . We have:

$$\lim_{V \rightarrow \infty} \langle 0 | [Q_V^\alpha(t), \phi_i(x)] | 0 \rangle \neq 0 \quad (3.12)$$

where the left hand side of the first equation is known as the *order parameter*. Let us examine this quantity.

$$\begin{aligned}
\langle 0|[Q_V^\alpha(t), \phi_i(x)]|0\rangle &= y \langle 0|\int_V d^3y [j^{0,\alpha}(y), \phi_i(x)]|0\rangle \\
&= \int_V d^3y \langle 0|[j^{0,\alpha}(y), \phi_i(x)]|0\rangle \\
&= \sum_n \int_V d^3y \langle 0|[j^{0,\alpha}(y), \phi_i(x)]|n\rangle \\
&= \int_V d^3y [\langle 0|j^0(y)|n\rangle \langle n|\phi_i(x)|0\rangle - \langle 0|\phi_i(x)|n\rangle \langle n|j^0(y)|0\rangle]
\end{aligned}$$

where we introduced an orthonormal set of states $|n\rangle$ (thus $\sum_n |n\rangle \langle n| = 1$). We subsequently find (3.12) to be:

$$\begin{aligned}
&\lim_{V \rightarrow \infty} \sum_n \int_V d^3\vec{x} [\langle 0|j^0(0)|n\rangle \langle n|\phi_i(y)|0\rangle e^{-iP_n \cdot x} - \langle 0|\phi_i(0)|n\rangle \langle n|j^0(0)|0\rangle e^{+iP_n \cdot x}] \\
&= \sum_n (2\pi)^3 \delta^3(\vec{P}_n) [\langle 0|j^0(0)|n\rangle \langle n|\phi_i(y)|0\rangle e^{-iE_n t} - \langle 0|\phi_i(0)|n\rangle \langle n|j^0(0)|0\rangle e^{+iE_n t}]
\end{aligned} \tag{3.13}$$

Here we used translation invariance of the ground state and $j^{0,\alpha}(x) = e^{ipx} j^{0,\alpha} e^{-ipx}$, while dropping the α superscript for convenience. We established in (3.11) time-independence of the quantity which was evaluated at the vacuum in (3.12) and (3.13). Now we impose both (3.13) and time-independence. Taking the time-derivative of (3.13), we find:

$$\sum_n E_n \delta^3(\vec{P}_n) [\langle 0|j^0(0)|n\rangle \langle n|\phi_i(0)|0\rangle e^{-iE_n t} + \langle 0|\phi_i(0)|n\rangle \langle n|j^0(0)|0\rangle e^{+iE_n t}] \neq 0 \tag{3.14}$$

up to a factor of $-i(2\pi)^3$. The only way to have this equation be time-independent and (3.13) nonvanishing is the existence of a state $|n\rangle$ such that $\langle 0|j^0(0)|n\rangle \langle n|\phi_i(0)|0\rangle \neq 0$ for a vanishing $E_n \delta^3(\vec{P}_n)$. We thus have a state with a energy (or *dispersion*) relation of the form

$$\lim_{\vec{P}_n \rightarrow 0} E_n = 0$$

which indeed corresponds to a massless particle. What can we say about this particle? Well, it should have the quantum numbers equal to those of j^0 and ϕ_i . For scalar theories, it should therefore be a boson.

3.1.3 Non-relativistic Goldstone bosons

In this section we will follow the paper by [Nielsen and Chadha (1976)] to develop the "counting" of Nambu-Goldstone bosons, and will review recent progress made in [Schäfer (2001)], [Watanabe and Brauner (2011)] and [Watanabe and Murayama].

We will start by assuming the following:

1. There is a symmetry group G of the theory, with m labeled generators Q_α spontaneously broken in the sense of (3.7). This requirement is usually restated as:

$$\det \langle 0 | [\phi_i, Q_\alpha] | 0 \rangle \neq 0 \quad \alpha, i = 1, \dots, m$$

for operators ϕ_i .

2. For any two local operators $A(x), B(x)$ we have:

$$| \langle 0 | [A(\vec{x}, t), B(0)] | 0 \rangle |_{|\vec{x}| \rightarrow \infty} \rightarrow e^{-\tau|\vec{x}|}$$

3. Translational invariance is not entirely broken in the sense of translational invariance of the vacuum and $j^{0,\alpha}(x) = e^{ipx} j^{0,\alpha} e^{-ipx}$ as encountered earlier.

We will discuss the necessity and meaning of these assumptions throughout our derivation. Let us consider again a Fourier transform of the quantity $\langle 0 | [\phi_i, j_\alpha^\mu] | 0 \rangle := M_{i\alpha}^\mu$ and will define $\langle 0 | [\phi_i, Q_\alpha] | 0 \rangle = M_{i\alpha}$. Even though our theory is non-relativistic, we will conveniently embed it in a framework where we introduced a time-like vector $n^\mu = (1, \vec{0})$. Following our assumptions we have once again:

$$\begin{aligned} \langle 0 | [Q_V^\alpha(t), \phi_i(x)] | 0 \rangle &= y \langle 0 | \int_V d^3y [j^{0,\alpha}(y), \phi_i(x)] | 0 \rangle \\ &= \int_V d^3y \langle 0 | [j^{0,\alpha}(y), \phi_i(x)] | 0 \rangle \end{aligned}$$

and thus upon a Fourier Transformation:

$$\langle 0 | [\phi_i, Q_\alpha] | 0 \rangle = \frac{1}{2\pi} \int dk e^{-ik^0 x^0} \delta(k) FT(M_{i\alpha}^0) \neq 0 \quad (3.15)$$

Where FT denotes "Fourier transformation of". We will denote $FT(M_{i\alpha}^\mu) = J_{i\alpha}^\mu$. In its most general form:

$$J_{i\alpha}^\mu = A_{i\alpha} k^\mu + B_{i\alpha} n^\mu \quad (3.16)$$

Again we impose current conservation, which in the Fourier transform amounts to:

$$k_\mu J_{i\alpha}^\mu = k^2 A_{i\alpha} + (k_\mu n^\mu) B_{i\alpha} = 0 \quad (3.17)$$

Now we find a general expression of the Fourier transform, denoting $n^\mu k_\mu = n \cdot k$:

$$A_{i\alpha} = \delta(k^2) \chi_{i\alpha}(n \cdot k) - (n \cdot k) \rho_{i\alpha}(k^2, n \cdot k) \quad (3.18)$$

$$B_{i\alpha} = \delta(n \cdot k) \Delta_{i\alpha}(k^2) + k^2 \rho_{i\alpha}(k^2, n \cdot k) + C_{i\alpha} \delta^4(k) \quad (3.19)$$

We note that through the inverse Fourier transform we have:

$$M_{i\alpha}^\mu = \frac{1}{(2\pi)^4} \int d^4k e^{ik \cdot x} J_{i\alpha}^\mu \quad (3.20)$$

which has a contribution $n^\mu C_{i\alpha}$ from the last term in (3.18), corresponding to a state with $k^\mu = 0$, an isolated energy state we want to avoid and indeed, our

second assumption prevents this term to make a contribution. We may note that $\delta(n \cdot k) \Delta_{i\alpha}(k^2)$ to make a contribution would imply a whole set of vacua with $k^0 = 0$ and different \vec{k} , as these are precisely the states with zero energy (thus $n \cdot k = 0$) but non-vanishing momenta. Fortunately this is also prevented by our third assumption - translational invariance may not be entirely broken.

Eliminating these two terms, we are left with two contributions, the former giving rise to dispersion relations of the form $E_{\vec{p}} \approx |\vec{p}|$, the latter to more general relations.

Let us now proceed to establish the counting of Nambu-Goldstone bosons in a non-relativistic setting. We will again introduce a complete set of orthonormal states:

$$M_{i\alpha}^\mu = \sum_{n=1}^l e^{-iE_k t} \langle 0 | \phi_i | n_k \rangle \langle n_k | j_\alpha^0 | 0 \rangle - e^{+iE_{-k} t} \langle 0 | j_\alpha^0 | n_{-k} \rangle \langle n_{-k} | \phi_i | 0 \rangle \Big|_{k=0} \quad (3.21)$$

with $|n_k\rangle$ a momentum eigenstate of a particle labeled by n . We know that for $k \rightarrow 0$, non-vanishing contributions will only be attained when $E \rightarrow 0$ simultaneously. We assumed in the notation above there will be l such states.

We will define a $m \times m$ matrix $\tilde{v}_{i\alpha} = \sum_{n=1}^l \langle 0 | \phi_i | n_0 \rangle \langle n_0 | j_\alpha^0 | 0 \rangle$ and can write, as is clear from (3.21) in the limit of $k \rightarrow 0$:

$$M_{i\alpha} = 2i \operatorname{Im} \tilde{v}_{i\alpha} \quad (3.22)$$

in the case of spontaneous broken symmetry, this implies $\operatorname{rank}(\operatorname{Im} \tilde{v}) = m$. We note that the columns \tilde{v}_a are linear combinations of the l column vectors:

$$A_n = \begin{pmatrix} \langle 0 | \phi_1 | n_0 \rangle \\ \langle 0 | \phi_2 | n_0 \rangle \\ \vdots \\ \langle 0 | \phi_m | n_0 \rangle \end{pmatrix} \quad (3.23)$$

which could be linearly dependent, and thus we establish $\operatorname{rank}(\tilde{v}) \leq l$. We may write:

$$v_a = \sum_{n=1}^l \gamma_{an} A_n \quad (3.24)$$

with $\gamma_{an} = \langle n_0 | j_\alpha^0 | 0 \rangle$. It follows immediately that we have:

$$\operatorname{Im} v_a = \sum_{n=1}^l \operatorname{Re} \gamma_{an} \operatorname{Im} A_n + \sum_{n=1}^l \operatorname{Im} \gamma_{an} \operatorname{Re} A_n \quad (3.25)$$

which expresses every column in $\operatorname{Im} \tilde{V}$ as a linear combination of $2l$ columns. And as we had established $\operatorname{rank}(\operatorname{Im} \tilde{v}) = m$ before, we must have $m \leq 2l$. This gives us a lower bound for the number of Goldstone bosons by $\frac{1}{2}m$.

We will now show that for $\frac{1}{2} \leq l \leq m$ there is at least one Goldstone boson which has, in the limit $k \rightarrow 0$, an energy proportional to an even power of

momentum. Denote $p = \text{rank} \tilde{v} \leq l$. We see there must exist $m - p$ independent linear relations among the vectors v_a :

$$\sum_{a=1}^m C_a^\alpha v_a = 0 \quad \alpha = 1, \dots, m - p \quad (3.26)$$

with C_a^α not all zero. Now this implies

$$\sum_{a=1}^m C_a^{\alpha*} v_a \neq 0 \quad (3.27)$$

This is because if this equality would hold, we would have a contradiction with our requirement $\text{rank}(\text{Im } \tilde{v}) = m$. (Take the real part of the coefficient and the imaginary part of the vector).

We will consider the quantity

$$\langle 0 | [\phi_i, \sum_{a=1}^m C_a^\alpha j_a^0(x)] | 0 \rangle \quad (3.28)$$

$$= \sum_{a=1}^m C_a^\alpha \sum_f \int \frac{d^3 p}{(2\pi)^3} [e^{ipx} \langle 0 | \phi_i | f_p \rangle \langle f_p | j_a^0 | 0 \rangle - e^{-ipx} \langle 0 | j_a^0 | f_p \rangle \langle f_p | \phi_i | 0 \rangle] \quad (3.29)$$

where we yet again introduced an intermediate set of states. We obtain a Fourier transform:

$$2\pi \sum_f \langle [\delta(k^0 - E_k) \sum_{a=1}^m C_a^\alpha \langle 0 | \phi_i | f_k \rangle \langle f_k | j_a^0 | 0 \rangle - \delta(k^0 + E_{-k}) \sum_{a=1}^m C_a^{\alpha*} \langle 0 | \phi_i | f_{-k} \rangle \langle f_{-k} | j_a^0 | 0 \rangle^*] \rangle$$

To fulfill the requirement of broken symmetry, the evaluated quantity should be non-vanishing for at least one ϕ_i for each α . Again, only states with $E \rightarrow 0$ for $\vec{k} \rightarrow 0$ can contribute. Let us examine the precise form of the dispersion law, by considering a neighborhood of $k = 0$, which boils down to dropping the first term in the previous equation to obtain:

$$-2\pi \sum_{n=1}^l \delta(k^0 + E_{-k}) \sum_{a=1}^m C_a^\alpha \langle 0 | \phi_i | n_{-k} \rangle \langle n_{-k} | j_a^0 | 0 \rangle |_{k \simeq 0} \quad (3.30)$$

We observe that (as $E \geq 0$) we should have $k^0 < 0$ for this to be non-vanishing. As we consider the region $k \simeq 0$ and thus $k^0 \simeq 0$, we conclude that the Fourier expansion around $k \simeq 0$ is a surface below and tangent to the plane $k^0 = 0$ and thus for $k \rightarrow 0$ is of the form $E \propto k^{2n}$, the dispersion relation for the corresponding Goldstone boson. To recap: we have shown there is at least one such Goldstone boson for $l < m$.

We will now show there are precisely $(m - p)$ Goldstone bosons of this particular type. This follows from the fact that it is impossible to find non-trivial constants β_α such that:

$$\sum_{\alpha=1}^{m-p} \beta_{\alpha} \sum_{a=1}^m C_a^{\alpha*} v_a = 0 \quad (3.31)$$

as this would imply

$$\sum_{a=1}^m \langle [\sum_{\alpha=1}^{m-p} (\beta_{\alpha} C_a^{\alpha*} + \beta_{\alpha}^* C_a^{\alpha})] \text{Im } v_a \rangle = 0 \quad (3.32)$$

which is once again a contradiction with $\text{rank}(Im\tilde{v}) = m$. Therefore we have $(m-p)$ linearly independent vectors q_i^{α} given by:

$$\sum_{a=1}^m C_a^{\alpha*} (v_a)_i = \sum_{n=1}^l \langle 0 | \phi_i | n_0 \rangle \langle n_0 | \sum_{a=1}^m C_a^{\alpha*} j_a^0 | 0 \rangle \quad (3.33)$$

and we therefore will end up with $(m-p)$ Goldstone bosons of this type, coupling to

$$\sum_{a=1}^m C_a^{\alpha} j_a^0 \quad \alpha = 1, \dots, m-p \quad (3.34)$$

To summarize: we have established the following result for the number of Goldstone bosons, denoting the bosons with an even power dispersion relation by n_{II} and the other (thus with odd power dispersion relation by n_I):

Theorem 3.4 (Nielsen-Chadha). *Following the assumption as stated in this section, for m spontaneously broken generators we have the following inequality:*

$$n_I + n_{II} \geq m \quad (3.35)$$

where n_I denotes the number of Goldstone modes with an odd dispersion relation $E \propto k^{2n+1}$ for $k \rightarrow 0$, while n_{II} denotes the number of Goldstone modes with even dispersion relation as $k \rightarrow 0$.

Proof.

$$n_I + 2n_{II} \geq l - (m-p) + 2(m-p) \geq m \quad (3.36)$$

□

Let us now examine present literature on conditions for this bound. We will start by a theorem due to [Schäfer (2001)].

Theorem 3.5. *If Q_i , with $i = 1, \dots, m$ is the full set of broken generators and for any pair (i, j) we have $\langle 0 | [Q_i, Q_j] | 0 \rangle = 0$, the number of Goldstone bosons is equal to the number of broken generators.*

Proof. Let us assume, for contradiction, there to be less than m Goldstone bosons. In that case, we can find a_i such that:

$$\sum_i a_i Q_i | 0 \rangle = 0 \quad (3.37)$$

As discussed previously, it is not necessarily true $\sum_i a_i Q_i$ is a Hermitian generator of a symmetry transformation. We can, however, take real and complex parts

to obtain such generators. Let Q_a denote the real part of the previous expression, while Q_b denotes the imaginary part. Now (3.37) yields that both $Q_a|0\rangle \neq 0$ and $Q_b|0\rangle \neq 0$. In fact, we have directly from (3.37):

$$(Q_a + iQ_b)|0\rangle = 0 \quad (3.38)$$

and hence $Q_a|0\rangle = |b\rangle$ and $Q_b|0\rangle = -i|b\rangle$, defining the state $|b\rangle$. Now we observe the commutator $\langle 0|[Q_a, Q_b]|0\rangle \neq 0$ which contradicts the initial assumption. \square

In [Watanabe and Brauner (2011)] this relation was explored further, arriving at the inequality:

$$n_{NG} - n_{BS} \leq \frac{1}{2} \text{rank} \rho \quad (3.39)$$

when n_{NG} is counted as in (3.36), with

$$i\rho_{ab} = \lim_{V \rightarrow \infty} \frac{1}{V} \langle 0|[G_a, Q_b]|0\rangle \quad (3.40)$$

The inequality in (3.37) was shown to hold for internal symmetries and conjectured to be an equality. A proof of the equality to hold for internal, not necessarily Lorentz invariant theories was given in a subsequent paper [Watanabe and Murayama] invoking an approach based on effective Lagrangians.

3.2 Spacetime Symmetries

So far, we have established a framework which is very useful for internal symmetries, in both a relativistic (here the number of Goldstone bosons is precisely the number of broken generators) and non-relativistic setting, where we established specific counting rules [(3.39) and (3.36)] and theorems [3.5]. For spacetime symmetries however, the situation is more complicated and case-dependent. We will follow a paper by [Low and Manohar] to formulate a theory in this case. Let us start by examining a continuous symmetry group G , with charges Q_A of $\dim G = m+n$ which spontaneously breaks down to a subgroup H with unbroken charges with $\dim H = n$ labeled by α and thus having m broken charges, labeled by a .

We will proceed in a way as we did when establishing inequalities in a non-relativistic setting (from equation (3.21) and onwards). We thus have n generators such that (following notation in [Low and Manohar]²):

$$Q^\alpha(x) \langle \phi(\vec{x}) \rangle = 0 \quad (3.41)$$

and m generators such that:

$$Q^a(x) \langle \phi(x) \rangle \neq 0 \quad (3.42)$$

²In section 3.1.3 we introduced a complete set of orthonormal momentum eigenstates as a basis to evaluate ϕ , here we will evaluate directly. It may be clear that the same argumentation holds in the context of our previous derivation but may be quite cumbersome in notation.

Note that the generators here explicitly depend on coordinates, as we are considering spacetime transformations (for an example we may again refer to the conformal generators in Table 1.2) The Goldstone modes correspond to fluctuations of the order parameter in the limit of long wavelengths (thus $k \rightarrow 0$):

$$\delta\phi(x) = c_A(x)Q^A(x) \langle\phi(x)\rangle \quad (3.43)$$

We noted that the number of Goldstone bosons will be equal to the number of linearly independent broken generators, thus we have to subtract the number of linearly independent nontrivial solutions of the form: $c_a Q^a \langle\phi(x)\rangle$. However, as suggested in the notation of (3.43), we may now have functions of spacetime $c_A(x)$ rather than constants. As only the broken generators contribute, our goal will be to find the number of linearly independent solutions to:

$$c_a Q^a \langle\phi(x)\rangle = 0 \quad (3.44)$$

In [Low and Manohar] an example of an infinitely long string is discussed. For the formal derivation we refer to this paper, however the reasoning why such solutions to (3.44) may exist is quite helpful. Consider the string with a ground state as in this figure:

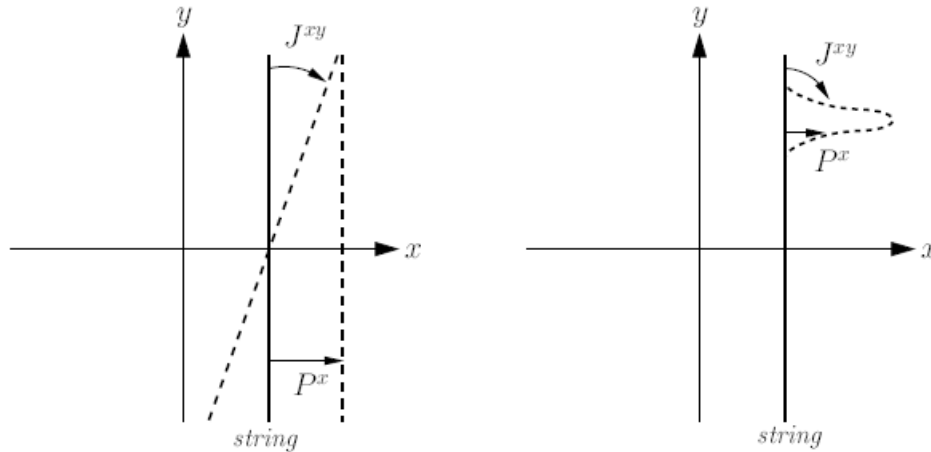

Figure 3.1: A string under both local and global translations and rotations. While the global rotation is distinct from the global translation, a local translation can be equivalent to a local rotation

We have the three dimensional Poincaré group being broken down to the two dimensional Poincaré group, thus having two spontaneously broken generators. The transformations corresponding to these broken generators, rotation in the xy -plane and translation on the x -axis, will globally lead to a different orientation of this string. However, if we allow for a local translation in the sense of the string being translated as a function of position as in the figure on the right, we see that this effect can be compensated by a local rotation and there is reason to expect a nontrivial solution to (3.44) to exist.

Let us conduct a more general discussion, starting with (3.44). Assuming unbroken translational invariance under P_μ (thus $c_a Q^a P_\mu \langle \phi(x) \rangle = 0$) we find:

$$\begin{aligned} 0 &= P_\mu c_a(x) Q^a \langle \phi(x) \rangle = [P_\mu, c_a(x) Q^a] \langle \phi(x) \rangle \\ &= -i(\partial_\mu c_a(x) Q^a - f^{\mu ab} c_a(x) Q^b) \langle \phi(x) \rangle \end{aligned} \quad (3.45)$$

where we wrote the commutator in a general form (in terms of all generators of the original symmetry group):

$$[P_\mu, Q^a] = i f^{\mu ab} Q^b + i f^{\mu a\beta} Q^\beta \quad (3.46)$$

where unbroken generators are labeled by β and broken generators by b . If there are some non-vanishing $f^{\mu ab}$ a non-trivial solution to (3.45) will satisfy:

$$(\partial_\mu c_a(x) - c_b(x) f^{\mu ab}) Q^a \langle \phi(x) \rangle = 0 \quad (3.47)$$

which associates the Goldstone modes corresponding to Q^a and Q^b . The key observation is a one-to-one correspondence between solutions of (3.47) and (3.44). We will see how this applies to conformal transformations in the next chapter.

Chapter 4

Nambu-Goldstone bosons and Conformal symmetries

In this chapter, we will elaborate on how conformal symmetry induces Nambu-Goldstone modes, following the results on spacetime symmetries in the previous chapter. We will see the relation between the number of broken symmetries and Nambu-Goldstone bosons to be non-obvious, and will attempt to arrive at an intuitive explanation for this fact.

4.1 Scale-invariant theories

It is a known fact that for a large class of theories, scale invariance implies invariance under the special conformal generators, see [Coleman and Jackiw (1971), Callan and Jackiw (1970)] amongst others. We will look to explore this relation further on in this chapter, but will for now focus on the study of theories which exhibit scale-invariance. Let us start by a scale transformation (known as a dilatation) on space-time coordinates:

$$x \mapsto lx \tag{4.1}$$

Now in the context of an action:

$$S = \int d^d x \mathcal{L}(x) \tag{4.2}$$

The measure $d^d x \mapsto d^d x' = l^d d^d x$ changes (denoting d the dimension of the theory we are considering). In order to have $\delta S = 0$, we require the Lagrangian to transform as:

$$\mathcal{L}(x') = \mathcal{L}(lx) = l^{-d} \mathcal{L}(x) \tag{4.3}$$

Let us consider a simple example:

$$\mathcal{L} = \frac{1}{2} \partial_\mu \phi \partial^\mu \phi \tag{4.4}$$

a free particle. Note that the derivatives transform as $\partial_\mu \mapsto l^{-1} \partial_\mu$ under a scaling transformation. As \mathcal{L} needed to have scaling dimension l^{-d} , the field ϕ should transform as:

$$\phi'(x') = \phi(lx) = l^{-(d-2)/2}\phi(x) \quad (4.5)$$

Let us take an infinitesimal scaling transformation $l = 1 + \epsilon$. We find subsequently:

$$\phi(x') = \phi((1 + \epsilon)x) = (1 + \epsilon)^{-(d-2)/2}\phi(x) \quad (4.6)$$

and hence:

$$\begin{aligned} \delta\phi &= \phi(x') - \phi(x) \\ &= (1 + \epsilon)^{(d-2)/2}\phi((1 + \epsilon)x) - \phi(x) \\ &= \epsilon\left[\frac{d-2}{2} + x^\mu\partial_\mu\right]\phi + O(\epsilon^2) \end{aligned} \quad (4.7)$$

which allows us to identify $[\frac{d-2}{2} + x^\mu\partial_\mu]$ as the generator of our symmetry transformation. Similarly, we can find:

$$\partial_\mu\delta\phi = \epsilon(d/2 + x^\nu\partial_\nu)\partial_\mu\phi \quad (4.8)$$

From which ($\delta\mathcal{L} = \frac{\delta\mathcal{L}}{\delta\phi}\delta\phi + \frac{\delta\mathcal{L}}{\delta\partial\phi}\delta\partial\phi$) we have:

$$\delta\mathcal{L} = -\epsilon\partial^\mu\phi(d/2 + x^\nu\partial_\nu)\partial_\mu\phi = \epsilon\partial_\mu(x^\mu\mathcal{L}) \quad (4.9)$$

which vanishes in the integral of the action under appropriate boundary conditions, and we can associate a current $\partial_\mu j^\mu = 0$. In the case of an extra mass term in the Lagrangian of the form $-\frac{1}{2}m^2\phi^2$, (4.9) will be:

$$\delta\mathcal{L} = \partial_\mu(x^\mu\mathcal{L}) + \left(\frac{d-2}{2}\right)m^2\phi^2 \quad (4.10)$$

which does not vanish in the integral, except for the case $d = 2$, where mass terms are allowed in a scale-invariant theory. Having established this, and the kinetic term to be scale-invariant as well, we seek to explore more general properties of scale-invariant theories, with a particular interest in those of dimension $d = 4$. We will restrict ourselves to the study of the interaction terms possible in scalar (thus bosonic) theories. A general interaction term will be of the form $-\alpha_n\frac{1}{n!}\phi(x)^n$ where α_n is a scalar, so from (4.5) we find this term to scale under $x \rightarrow lx$ as:

$$-\alpha_n\frac{1}{n!} \rightarrow -\alpha_n\frac{1}{n!}l^{-n(d-2)/2}\phi^n \quad (4.11)$$

Recall from (4.3) we need this term to scale as l^{-d} in a scale-invariant theory, so we have:

$$n(d-2)/2 = d \quad (4.12)$$

which has solutions

$$\frac{1}{n} + \frac{1}{d} = \frac{1}{2} \quad (4.13)$$

which allows solutions of $n = 6$ for $d = 3$ and $n = 4$ for $d = 4$, amongst others.

Let us return to the Noether current. We have from (4.10) for a scalar theory with a mass term a conserved current up to this mass term (vanishing in $d = 2$), thus

$$\partial_\mu s^\mu = \Delta \quad (4.14)$$

denoting the mass-dependent quantity in the previous expression by Δ (in general, this Δ may have additional terms and is a measure for the theory to be scale invariant). This current is the object we want to examine in our further discussion.

4.2 Scale invariance and conformal invariance - a first relation

Let us continue the discussion as initiated in section 2.1.1. We will revisit Table 1.2. As we can associate the energy-momentum tensor with the translational generator $-i\partial_\mu$ and the generator of scale-invariance with a conserved $s^\mu = x_\nu \theta^{\mu\nu}$ (we denoted the tensor by θ as its direct relation to the canonical energy-momentum tensor is unclear for now) it is natural to associate the special conformal generator with a tensor of the form:

$$K^{\lambda\nu} = x^2 \theta^{\lambda\nu} - 2x^\lambda x_\rho \theta^{\rho\nu} \quad (4.15)$$

we evaluate:

$$\partial_\mu K^{\lambda\mu} = 2x_\mu \theta^{\lambda\mu} - 2x_\rho \theta^{\rho\lambda} - 2x^\lambda \theta^\rho_\rho \quad (4.16)$$

which vanishes whenever the scale current is conserved, and thus scale invariance implies the conservation of currents induced by special conformal invariance. We should ask, however, under which conditions these relations are justified.

Let us explore these conditions a little bit. We thus have a current associated with dilatations s^μ

$$s^\mu = x_\nu \theta^{\mu\nu} \quad (4.17)$$

In case $\partial^\mu s_\mu = 0$ we have:

$$\partial^\mu s_\mu = \theta^\mu_\mu = 0 \quad (4.18)$$

We can give a more precise requirement for the existence of a tensor satisfying this equation by considering a Lorentz transformation:

$$\delta^{\mu\nu} \phi = [x^\mu \delta^\nu - x^\nu \partial^\nu + \Sigma^{\mu\nu}] \phi = \partial_\nu \sigma^{\mu\nu} \quad (4.19)$$

where $\Sigma^{\mu\nu}$ is known as the spin matrix, which we mentioned earlier. The necessary and sufficient condition for the existence of our desired tensor is [Coleman (1971), Chapter 3]:

$$\frac{\partial \mathcal{L}}{\partial(\partial_\nu \phi)} [g^{\mu\nu} d + \Sigma^{\mu\nu}] \phi = \partial_\nu \sigma^{\mu\nu} \quad (4.20)$$

which we will state without providing proof. Here $\sigma^{\mu\nu}$ is a tensor function of (derivatives of) fields. In [Coleman (1971), Weinberg (1995a)] conditions for such a tensor are explored further and are satisfied for a large class of renormalizable theories.

4.3 Dilatations and Goldstone bosons

It is time to pick up where we left of at the end of the third Chapter, of which the last section will serve as a basis for this discussion. In Table 1.2 we arrived at the commutation relation (1.38):

$$[K_\mu, P_\nu] = 2i(\eta_{\mu\nu}D - L_{\mu\nu}) \quad (4.21)$$

thus in the case of Lorentz invariance:

$$[P_\nu, K_\mu] \langle \phi(x) \rangle = -2i\eta_{\mu\nu}D \langle \phi(x) \rangle \quad (4.22)$$

which, in light of (3.47) guarantees the existence of a $f^{\mu ab}$ required and thus leads us to conclude we can eliminate the Goldstone mode of special conformal transformations in favour of the Goldstone mode associated with dilatation in the case of invariance under rotations and translations.

4.4 Conformal transformations, a final discussion

We will now review a paper [Guillen] which should clarify the discussion in sections 4.1 and 4.2 which were somewhat less rigorous of nature and will conclude this chapter. The main purpose is to derive the existence of conserved currents in terms of the Canonical and Symmetric Energy Momentum Tensors (CEMT and SEMT) from the definition of a conformal transformation, clarifying the somewhat vague results in previous sections. We start off with a definition of conformal transformations (see Definition 1.36) of the metric:

$$g_{\mu\nu} = \lambda(x)\eta_{\mu\nu} \quad (4.23)$$

Infinitesimally $\lambda(x) = 1 + \Omega(x)$ and we find¹:

$$\bar{\delta}\eta_{\mu\nu} := g_{\mu\nu}(x) - \eta_{\mu\nu} = \Omega(x)\eta_{\mu\nu} \quad (4.24)$$

Under infinitesimal coordinate transformations

$$x^{\mu'} = x^\mu + \delta x^\mu(x) \quad (4.25)$$

we find (4.24) to reduce to:

$$\bar{\delta}\eta_{\mu\nu} = -\eta_{\mu\rho}\partial_\nu\delta x^\rho - \eta_{\nu\rho}\partial_\mu\delta x^\rho \quad (4.26)$$

and combining these equations we have:

$$\eta_{\mu\rho}\partial_\nu\delta x^\rho + \eta_{\nu\rho}\partial_\mu\delta x^\rho = \frac{1}{2}\eta_{\mu\nu}\partial_\rho\delta x^\rho \quad (4.27)$$

known as the *conformal killing equation* with $\Omega(x) = \frac{1}{2}\eta_{\mu\nu}\partial_\rho\delta x^\rho$. Solutions to this equation are precisely the ones given by the conformal group, as derived

¹As $g_{\mu\nu}$ is non-constant, we should remark we evaluate this metric at the point of transformation

in Chapter 1. Let us now consider a theory with an infinitesimal transformation of a field (4.25) inducing a transformation of the Lagrangian similar to (2.7), as familiar but with an extra term corresponding to a change in metric:

$$\delta\mathcal{L} = \bar{\delta}\mathcal{L} + \delta x^\mu \partial_\mu \mathcal{L} \quad (4.28)$$

where

$$\bar{\delta}\mathcal{L} = \frac{\partial\mathcal{L}}{\partial\phi}\delta\phi + \frac{\partial\mathcal{L}}{\partial(\partial_\mu\phi)}\partial_\mu(\delta\phi) + \frac{\partial\mathcal{L}}{\partial\eta_{\mu\nu}}\bar{\delta}\eta_{\mu\nu} \quad (4.29)$$

The variation of the Lagrangian can be expressed in terms of the SEMT (2.11):

$$\frac{\partial\mathcal{L}}{\partial\eta_{\mu\nu}} = -\frac{1}{2}\sqrt{\det\eta}T^{\mu\nu} \quad (4.30)$$

Now let us consider an action invariant under transformations of coordinates (4.25) and field:

$$\delta\phi = \phi'(x) - \phi(x) + \delta x^\mu \partial_\mu \phi \quad (4.31)$$

giving (4.28):

$$\Delta\mathcal{L} = \mathcal{L}\partial_\mu\delta x^\mu + \bar{\delta}\mathcal{L} + \delta x^\mu \partial_\mu \mathcal{L} = 0 \quad (4.32)$$

in order for $\delta S = 0$ to hold. In very similar fashion to our derivation in Chapter 2 we find:

$$\left(\frac{\partial\mathcal{L}}{\partial\phi} - \partial_\mu\frac{\partial\mathcal{L}}{\partial(\partial_\mu\phi)}\right)\delta\phi + \partial_\mu\left(\frac{\partial\mathcal{L}}{\partial(\partial_\mu\phi)}\delta\phi\right)\bar{\delta}\phi - \partial_\mu j^\mu = -\frac{\partial\mathcal{L}}{\partial\eta_{\mu\nu}}\bar{\delta}\eta_{\mu\nu} \quad (4.33)$$

with the usual current

$$j^\mu = -\frac{\partial\mathcal{L}}{\partial(\partial_\mu\phi)}\bar{\delta}\phi - \mathcal{L}\delta x^\mu \quad (4.34)$$

when the equations of motion are satisfied, we arrive at a current which is conserved up to the right-hand side of (4.33). For isometries such as translations and Lorentz transformations we will arrive at the usual CEMT and *Total Angular Momentum Tensor*. The case of transformations which are not isometries (thus dilatations and special conformal transformations) are the ones of particular interest to us, however and will be discussed here.

We already obtained an equation for infinitesimal dilatations in (4.7). To stay in the language of the paper reviewed we will rewrite the relations obtained:

$$\bar{\delta}\phi = -a(x^\mu\partial_\mu\phi + d\phi) \quad (4.35)$$

where d is now called the *scale dimension*, a notion familiar in QFT. If we substitute this equation in (4.29) using $\bar{\delta}\eta_{\mu\nu} = -2a\eta_{\mu\nu}$ under a dilatation $\delta x^\mu = ax^\mu$ we find:

$$\bar{\delta}\mathcal{L} = a(-x^\mu\partial_\mu\mathcal{L} - d\frac{\partial\mathcal{L}}{\partial\phi}\phi - (d+1)\frac{\partial\mathcal{L}}{\partial(\partial_\mu\phi)}\partial_\mu\phi + T^\mu_\mu) \quad (4.36)$$

using translational invariance of the action, we are now ready to evaluate (4.32):

$$\Delta\mathcal{L} = a(4\mathcal{L} - d\frac{\partial\mathcal{L}}{\partial\phi}\phi - (d+1)\frac{\partial\mathcal{L}}{\partial(\partial_\mu\phi)}\partial_\mu\phi + T_\mu^\mu) \quad (4.37)$$

Requiring $\Delta\mathcal{L} = 0$ implies:

$$4\mathcal{L} = d\frac{\partial\mathcal{L}}{\partial\phi}\phi + (d+1)\frac{\partial\mathcal{L}}{\partial(\partial_\mu\phi)}\partial_\mu\phi - T_\mu^\mu \quad (4.38)$$

substituting this equation in (4.36) gives:

$$\bar{\delta}\mathcal{L} = -ax^\mu\partial_\mu\mathcal{L} - 4a\mathcal{L} \quad (4.39)$$

We will now substitute $\delta x^\mu = ax^\mu$, $\bar{\delta}\eta_{\mu\nu} = -2a\eta_{\mu\nu}$, (4.30) and (4.35) in (4.28) to find:

$$\partial_\mu s^\mu = T_\mu^\mu \quad (4.40)$$

in suggestive notation, with

$$s^\mu = x^\nu t_\nu^\mu + d\frac{\partial\mathcal{L}}{\partial(\partial_\mu\phi)}\phi \quad (4.41)$$

the dilatation current. We have thus identified the relation in (4.14) and validated the somewhat imprecise argumentation in that section. One can carry out a very similar analysis on the special conformal generator to find:

$$\partial_\mu K_\nu^\mu = 2x_\nu T_\mu^\mu \quad (4.42)$$

with

$$K_\nu^\mu = 2x_\nu x^\rho t_\rho^\mu + 2dx_\nu\frac{\partial\mathcal{L}}{\partial(\partial_\mu\phi)}\phi - x_\rho x^\rho t_{\nu\mu}^\mu - 2x^\rho S_{\nu\rho}^\mu \quad (4.43)$$

where the last term contains a tensor derived from the Spin tensor $\Sigma^{\mu\nu}$ by:

$$S_{\mu\nu}^\rho = i\frac{\partial\mathcal{L}}{\partial(\partial_\rho\phi)}\phi\Sigma^{\mu\nu}$$

so for both s^μ and K_ν^μ there exists conserved currents only if the trace of the SEMT vanishes, which is true for massless theories as we established earlier.

We may conclude that an early discussion in the first section of this chapter on the theories exhibiting scale invariance indeed led to a proper conclusion on the requirement of no mass terms. In fact, we may conclude the same thing for special conformal transformations. Furthermore, we have established that under the assumption of translational invariance the observations in section 4.2 are indeed valid. We should also emphasize the counting theorems in section 3.1 not to be applicable due to the non-trivial solutions of (3.43) which indeed are dependent on coordinates, as we have seen in this section.

Conclusion and Outlook

Let us recap on the results in thesis and examine the room for exploration in further research. We introduced the language of (Lie) Group Theory as our language to discuss symmetry transformations. In particular, establishing the Lie Algebra as the generators for transformation turned out to be a powerful framework to define elements in the conformal group.

In the second chapter we saw the existence of a variational equation for physical systems leading to a natural notion of symmetries in terms of the action and Lagrangian. We derived Noether's theorem, arriving at conserved currents and charges. We established the latter to be the generators (thus the Lie Algebra) of the corresponding transformations.

Furthermore, we established Goldstone's theorem in various contexts (relativistic and non-relativistic, internal and space-time symmetries), relating the number of broken charges to the number of Goldstone modes in a review of the literature currently available.

We focused specifically on conformal symmetries and their Goldstone modes in the last chapter, establishing subsequently the possible theories exhibiting conformal invariance, finding relations between dilatations and special conformal transformations and counting of Goldstone bosons. A full justification of observations made in the preceding sections was given in the final section of this thesis. We established a direct connection between the SEMT (Symmetric Energy Momentum Tensor), conformal invariance and conserved tensors corresponding to dilatations and special conformal transformations as being locally indistinguishable.

For further research, we suggest exploring the connection between dilatations and special conformal transformations for a theory in which translational invariance is broken, disconnecting the two and thus their Goldstone modes. One could start by examining theories which exhibit scale invariance without conformal invariance, as examined in [Jean-Francois Fortin] and [Nakayama] amongst others.

Appendices

Appendix A

Notation

Let us briefly review the notation used throughout this thesis.

As a rule, Latin indices i, j, k etc. will indicate spatial coordinates (running through 1, 2, 3), while Greek indices μ, ν etc. indicate spacetime coordinates (and will thus run through 0, 1, 2, 3) with x^0 indicating the time coordinate.

Spatial vectors will be denoted \vec{x} or \mathbf{x} and spacetime vectors by x .

Repeated indices are summed over and may be omitted altogether when the indexing is clear from the context, adapting a notation $x^\mu y_\mu = x \cdot y$.

The spacetime Minkowski metric $\eta_{\mu\nu}$ is diagonal with elements $\eta_{00} = 1$, $\eta_{11} = \eta_{22} = \eta_{33} = -1$.

Generally tensors are denoted with capital Latin or Greek letters. Vectors, scalars and functions are usually denoted by noncapital letters.

Functions may be denoted either with or without arguments (i.e. f or $f(x)$), the latter applying when arguments are clear from context.

The complex conjugate, transpose and adjoint of a matrix or vector A are denoted by A^* , A^T and $A^\dagger = A^{*T}$ respectively.

Appendix B

Group Theory

We will briefly state basic definitions and theorems necessary to follow its use in the Chapters 2 through 4. This Appendix is based on [Lang (2005)], which contains a more elaborate introduction.

Definition B.1 (Group). A *group* is a set equipped with an operation $\{G, \cdot\}$ such that;

1. $a \cdot b \in G$ for all $a, b \in G$
2. There is an element in G , denoted by 1 such that $1 \cdot a = a \cdot 1 = a$ for all $a \in G$
3. For each element $a \in G$, there exists an element $a^{-1} \in G$ such that $a \cdot a^{-1} = a^{-1} \cdot a = 1$
4. we have associativity, thus $a \cdot (b \cdot c) = (a \cdot b) \cdot c$ for all $a, b, c \in G$

Definition B.2 (Abelian Groups). A group $\{A, \cdot\}$ is called *Abelian* when it is commutative, thus $a \cdot b = b \cdot a$ for all $a, b \in A$.

In the following we will drop the \cdot operator, thus denoting a group by G and multiplication by ab . Now let us see how to define a group. For finite groups, one may simply list the elements $\{1, a_1, \dots, a_n\}$ and write down a table of size $(n + 1) \times (n + 1)$ with elements $M_{ij} = a_i a_j$. One may also define it in another way. Let us take the integers \mathbb{Z} as an example, with group operation being addition. One can start off with the number one and construct all other elements by addition or subtraction (note $1^{-1} = -1$). We may therefore define the group $(\mathbb{Z}, +)$ by its generating element $\{1\}$ and a rule of construction. For continuous groups (a notion not well-defined here) like \mathbb{R} we will see they may be generated by *infinitesimal generators*, a notion very important in our discussion on Lie Algebras.

We will now discuss mappings between groups.

Definition B.3 (Homomorphism). A map $f : N \rightarrow M$ between groups is called a *homomorphism* if for every $a, b \in N$:

$$f(ab) = f(a)f(b)$$

it is called an *isomorphism* when it is both a homomorphism and a bijection and an *automorphism* when $N = M$.

Intuitively, homomorphisms preserve group structure. It is easy to show that $f(x^{-1}) = f(x)^{-1}$ for $x \in N$ and it maps identity elements to identity elements.

Let us (without proof) establish some important basic results.

Theorem B.4. *Let f be a homomorphism between groups $f : G \rightarrow G'$*

1. *If the kernel of f is trivial, then f is an isomorphism of G with its image $f(G)$.*
2. *If f is surjective and the kernel of f is trivial, then f is an isomorphism.*

Corollary B.5 (Conjugation). *Let G be a group and $a \in G$. The conjugation mapping $c_a G \rightarrow G$ given by $c_a(g) = aga^{-1}$ is an automorphism.*

We will now proceed to find partitions of groups. First, let us define

Definition B.6 (Subgroups and cosets). A *subgroup* is a subset H of a group G closed under the group operation. A *coset* aH of a subgroup H and element $a \in G$ is defined as the set $\{ah \mid h \in H\}$

the set of cosets induced by the subgroup H is denoted by G/H . note that a coset may not be closed under the group operation and we thus cannot simply state them to be groups. We can find a partition in terms of cosets however:

Theorem B.7. *Let aH and bH be cosets of the subgroup H in the group G . Either these cosets are equal, or they have no elements in common.*

Let us now proceed to discuss a more specific class of subgroups, the *normal* subgroups.

Definition B.8. A subgroup H of G is called *normal* when $xHx^{-1} = H$ for all $x \in G$.

it is clear what the set xHx^{-1} denotes. We will now list several theorems regarding normal subgroups, which will stress their importance:

Theorem B.9. *Let G be a group and H be a normal subgroup.*

1. *H is the kernel of a homomorphism between G and some other group.*
2. *The collection of cosets is, with the product $(aH)(bH)$ also a group.*
3. *The map $f : G \rightarrow G/H$ mapping each element into its corresponding coset is a homomorphism with kernel H .*

Corollary B.10. *Let $f : G \rightarrow G'$ be a homomorphism, and let H be its kernel. Then the association $xH \mapsto f(xH)$ is an isomorphism of G/H with the image of f .*

Appendix C

Quantum Mechanics

We will now review the basics of Quantum Mechanics (QM) and Quantum Field Theory (QFT). This Appendix is based on both [Griffiths (2005)] and [Tong], which serve as our references for further reading.

In QM, one has rather than a point with definite spacetime coordinates a wavefunction describing the state of a system. This wavefunction may either be composite or singleton and is governed by the famous Schrödinger equation, which reads in one dimension:

$$i\hbar \frac{\partial \psi}{\partial t} = -\frac{\hbar^2}{2m} \frac{\partial^2 \psi}{\partial x^2} + V\psi \quad (\text{C.1})$$

where \hbar is the reduced constant of Planck and V the relevant potential. The wavefunctions have a probabilistic interpretations in the sense that the probability of finding a particle corresponding to ψ between a and b is given by $\int_a^b dx |\psi|^2$. For time-independent potentials one can rewrite the Schrödinger equation:

$$H\psi = E\psi \quad (\text{C.2})$$

where H is the Hamiltonian operator, given by identifying the righthand side of the previous equation with $H\psi$ and E is a constant, the energy of the state ψ . Now QM is written in the language of Linear Algebra, i.e., the states are vectors in a Hilbert space and may be denoted by $|\psi\rangle$, with inner product:

$$\langle \psi | \psi \rangle = \int dx \psi^\dagger \psi \quad (\text{C.3})$$

Observables correspond to Hermitian operators and their quantities are given by $\langle \psi | O | \psi \rangle$, often denoted simply as $\langle O \rangle$. Important examples are the *momentum* operator, given by $P_x = -i\frac{\partial}{\partial x}$ and the Hamiltonian, $H = -\frac{\hbar^2}{2m} \frac{\partial^2}{\partial x^2} + V$.

When unifying special relativity (SR) and QM, one naturally arrives in QFT. The fields are governed by equations of motion, which can be expressed in terms of either the Lagrangian (see Chapter 2) or the Hamiltonian (as familiar in QM). However, one usually prefers the former as this is a variational equation. In SR, invariance of the Minkowski metric gives rise to a symmetry group known as the *Lorentz group*, consisting of all rotations and boosts (in words - moving between reference frames). Formally, these are all transformations such that $\Lambda^T \eta \Lambda = \eta$.

An extension of this group is the *Poincaré group*, which includes translations.

A *theory* in QFT is a specific Lagrangian acting on a field (this may be scalar valued, but also vector valued etc.). A probabilistic interpretation is obtained by promoting the field and its *conjugate momentum* given by $\pi = \frac{\partial \mathcal{L}}{\partial \dot{\psi}}$ and promoting these to operators with commutation relations known from QM. See [Tong] for a detailed discussion.

Bibliography

- Coleman S. Callan, C. and R. Jackiw. A new improved energy-momentum tensor. *Ann. Phys.*, 59:42–73, 1970.
- S. Coleman. *Aspects of Symmetry - selected Erice Lectures*. Cambridge University Press, 1971.
- S. Coleman and R. Jackiw. Why dilatation generators do not generate dilatations. *Ann. Phys.*, 67:552–598, 1971.
- Mathieu & Sénéchal Di Francesco. *Conformal Field Theory*. Springer, 1997. ISBN 0-387-94785.
- J.J. Duistermaat and J.A.C. Kolk. *Lie Groups*. Universitext. Springer, 2000. ISBN 3-540-15293-8.
- John Ove Fjaerestad. The heisenberg model. <http://folk.ntnu.no/johnof/magnetism-2012.pdf>. [Online; accessed May-2017].
- W. Fulton and J. Harris. *Representation Theory*. Readings in mathematics. Springer, New York, 2005. ISBN 0-387-97495-4.
- Paul Garrett. Conformal mapping. http://www-users.math.umn.edu/~garrett/m/complex/notes_2014-15/07_conformal_mapping.pdf. [Online; accessed May-2017].
- D.J. Griffiths. *Introduction to Quantum Mechanics*. Pearson Education International, Upper Saddle River, New Jersey, 2005.
- L.C.T. Guillen. Remarks on the conformal transformations. arXiv:hep-th/0408077v1. [Online; accessed May-2017].
- Andreas Stergiou Jean-Francois Fortin, Benjamn Grinstein. Scale invariance without conformal invariance. arXiv:hep-th/1107.3840. [Online; accessed June-2017].
- H.F. Jones. *Groups, Representations and Physics*. Taylor & Francis Group, New York, 1998. ISBN 0-7503-0504-5.
- Alexander Kirillov. Introduction to lie groups and lie algebras. <http://www.math.stonybrook.edu/~kirillov/>. [Online; accessed April-2017].
- S. Lang. *Undergraduate Algebra*. Undergraduate texts in mathematics. Springer, Praha, 2005. ISBN 0-387-22025-9.

- I. Low and A.V. Manohar. Spontaneously broken spacetime symmetries and goldstone's theorem. arXiv:hep-th/0110285v2. [Online; accessed May-2017].
- Yu Nakayama. Scale invariance vs conformal invariance. arXiv:hep-th/1302.0884. [Online; accessed June-2017].
- H.B. Nielsen and S. Chadha. On how to count goldstone bosons. *Nuclear Physics*, B105:445–453, 1976.
- T. et al. Schäfer. Kaon condensation and goldstone's theorem. *Physics Letters B*, 522:67–75, 2001.
- M. Schottenloher. *A Mathematical Introduction to Conformal Field Theory*. Universitext. Springer, 2008.
- D. Tong. Quantum field theory. <http://www.damtp.cam.ac.uk/user/tong/qft/qft.pdf>. [Online; accessed May-2017].
- H. Watanabe and T. Brauner. Spontaneous breaking of continuous translational invariance. arXiv:1112.3890v2. [Online; accessed April-2017].
- H. Watanabe and T. Brauner. Number of nambu-goldstone bosons and its relation to charge densities. *Physical Review D*, 84, 2011.
- H. Watanabe and H. Murayama. Unified description of nambu-goldstone bosons without lorentz invariance. arXiv:1203.0609. [Online; accessed May-2017].
- S. Weinberg. *The Quantum Theory of Fields, Volume I*. Cambridge University Press, Cambridge, 1995a. ISBN 978-0-521-67053-1.
- S. Weinberg. *The Quantum Theory of Fields, Volume II*. Cambridge University Press, Cambridge, 1995b. ISBN 978-0-521-67054-8.

List of Figures

1.1	A square with undirected sides	4
1.2	A square with directed sides	5
1.3	An $\mathbb{R} \rightarrow \mathbb{R}^2$ immersion of a line segment	15
2.1	A potential symmetric under $\phi \mapsto -\phi$	36
2.2	A potential symmetric under $\phi \mapsto -\phi$ with small perturbation	37
3.1	A string under both local and global translations and rotations. While the global rotation is distinct from the global translation, a local translation can be equivalent to a local rotation	51

List of Tables

1.1	Remaining invariant transformations in undirected square	5
1.2	Generators of the conformal group	28